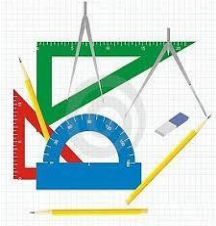

Government of Karnataka
Department of Technical Education
Board of Technical Examinations, Bengaluru

	Course Title: ENGINEERING DRAWING-II		
	Credits (L:T:P) : 0:2:4	Total Contact Hours: 78	Course Code: 15CE22D
	Type of Course: Tutorial and Drafting	Credit :03	Core/ Elective: Core
CIE- 25 Marks		SEE- 100 Marks	

(*Common to all Civil Engineering /Civil (Draughtsman/Environmental/Public Health Engineering/Water Technology and Health Sciences Programme)***)**

Prerequisites: Student should know Engineering Drawing-I

Course Objectives

1. The course is aimed at developing Basic Drawing skills.
2. Develop Skills in Preparation of Engineering Drawings.
3. Develop Skills In Preparation of Engineering Drawings, their Reading and Interpretation

Course Outcomes

On successful completion of the course, the students should be able to:

Course Outcome		CL	Linked PO	Teaching Hrs
CO1	Draw Orthographic views of given Civil Engineering Objects.	R/U/Ap/Ay	1,2,3,4,5,8,9,10	15
CO2	Develop the ability to draw the isometric view from the orthographic views of a given Building Components and vice versa.	U/Ap/Ay	1,3,8,9	21
CO3	Develop the perspective views for simple Civil Engineering components	R/U/Ap/Ay	1,2,3,5,8,9	12
CO4	Build up the concept of developing cross sections for Building components.	R/U/Ap/Ay	1,2,3,5,8,9,10	09
CO5	Develop Plan and Elevation for single and two room Buildings for sustainable development as per codal provisions	R/U/Ap/Ay	1,2,3,4,5,6,7,8,9,10	21
Total sessions				78

Legend- R; Remember U: Understand Ap: Application Ay: Analysis C:Creation E: Evaluation

Programme outcome Attainment Matrix

Course	Programme Outcome									
	PO1	PO2	PO3	PO4	PO5	PO6	PO7	PO8	PO9	PO10
	Basic knowledge	Discipline knowledge	Experiments and practice	Engineering Tools	Engineer and society	Environment & Sustainability	Ethics	Individual and Team work	Communication	Life long learning
ENGINEERING DRAWING-II	3	3	3	3	3	2	2	3	3	3

Level 3- Highly Addressed, Level 2-Moderately Addressed, Level 1-Low Addressed.

Method is to relate the level of PO with the number of hours devoted to the COs which address the given PO.

If $\geq 40\%$ of classroom sessions addressing a particular PO, it is considered that PO is addressed at Level 3

If 25 to 40% of classroom sessions addressing a particular PO, it is considered that PO is addressed at Level 2

If 5 to 25% of classroom sessions addressing a particular PO, it is considered that PO is addressed at Level 1

If $< 5\%$ of classroom sessions addressing a particular PO, it is considered that PO is considered not-addressed.

Course Contents

UNITS	COURSE CONTENTS	HOURS
1	PROJECTION OF SOLIDS Introduction-Positioning of solids –Solid lying with base on HP- Solids lying with base or axis inclined to HP- Solids lying with one of the lateral faces on HP- Solids lying with one of their lateral edges on HP-Cylinder lying with its axis or base inclined to HP- Cone lying with its axis or base inclined to HP -Solid lying with their axis inclined to both HP and VP.	15
2	CONVERSION OF ISOMETRIC VIEWS INTO ORTHOGRAPHIC VIEWS Introduction –Guidelines for conversion of pictorial views into orthographic views-Illustrative problems.	06
3	ISOMETRIC VIEWS Principles of isometric Views Isometric views of simple solids – cube – prisms, pyramids, cylinder and cone . Conversion of orthographic views into isometric View Drawing of Isometric views of combination of solids , Civil Engineering components i.e. column footing, carpentry joints	15
4	PERSPECTIVE PROJECTIONS Technical terms used in perspective projection- one point Perspective projection and two point perspective projection for simple objects like Cube, Prism, Pyramids, combination of solids and simple civil engineering objects.	12
5	CROSS SECTION OF BUILDING COMPONENTS Conventional Representation of Civil Engineering materials. Cross section of Wall showing components of a Building from parapet to foundation through door, window, wardrobe, wall, steps & columns.	09
6	BUILDING DRAWING Draw Plan, Elevation and Section for Single ,Double Room Building and Three Room Building form the given line Diagram and Building details.	21
	Total	78 Hrs

Note: Grade exercises Plan in each unit should be as per table provided below.

Course Delivery: The course will be delivered through lectures with classroom practices and Power point presentations/ Video.

Course Assessment and Evaluation Scheme:

Method	What		To whom	When/Where (Frequency in the course)	Max Marks	Evidence collected	Course outcomes
Direct Assessment	CIE	IA	Students	Graded Exercises (Average of marks allotted to each graded exercise)	25	Drawing Sheets	1,2,3,4,5
	SEE	End Exam		End of the course	100	Answer scripts at BTE	1,2,3,4,5
Indirect Assessment	Student Feedback on course		Students	Middle of the course		Feedback forms	1, 2,3 ,Delivery of course
	End of Course Survey			End of the course		Questionnaires	1,2,3,4,5Effectiveness of Delivery of instructions & Assessment Methods

Weightage of Marks and blue print of marks for SEE

Unit	Major Topics	Hours Allotted	Questions to be set for SEE						Marks weightage	weightage (%)	A*	B*	C*
			Cognitive Levels										
			R	U	Ap	Ay	C	E					
1	Projection of solids	15	15%	35%	30.00%	20.00%	0.00%	0.00%	26	18		2	
			4	10	7	5	0	0					
2	Conversion of pictorial views into orthographic views	6	0%	20%	40.00%	40.00%	0.00%	0.00%	12	8	1		
			0	2	5	5	0	0					
3	Isometric projections	15	0.00%	20.0%	40.00%	40.00%	0.00%	0.00%	27	19		2	
			0	5	11	11	0	0					
4	Perspective projections	9	10.00%	40.0%	40.00%	20.00%	0.00%	0.00%	19	12		1	
			2	7	7	3	0	0					
5	Cross section of building components	9	15.00%	30.00%	30.00%	20.00%	0.00%	0.00%	16	12	2		
			3	5	5	3	0	0					
6	Building drawing	24	15.00%	25.00%	40.00%	20.00%	0.00%	0.00%	40	31			1
			6	10	16	8	0	0					
Total		78						140	100	3	5	1	

Legend- R; Remember U: Understand Ap: Application Ay: Analysis C:Creation E: Evaluation

A*-SEE QUESTIONS TO BE SET FOR (10MARKS) in PART – A(any 2 out of 3)

B*- SEE QUESTIONS TO BE SET FOR (15MARKS) in PART – B(any 2 out of 5)

C*- SEE QUESTIONS TO BE SET FOR (35MARKS) in PART – C(Compulsory)

Questions for CIE and SEE will be designed to evaluate the various educational components such as:

Sl. No	Bloom's taxonomy	% in Weightage
1	Remembering and Understanding	38
2	Applying the knowledge acquired from the course	31
3	Analysis	23
4	Synthesis (Creating new knowledge)	0
5	Evaluation	0

GRADED EXERCISES

UNIT NO	NAME OF THE UNIT	SHEETS	TITLE OF THE DRAWING	MINIMUM NO OF EXERCISE
I	PROJECTION OF SOLIDS	5	Projection of solids	20
II	CONVERSION OF ISOMETRIC VIEWS INTO ORTHOGRAPHIC VIEWS	3	Isometric projections	15
III	ISOMETRIC PROJECTIONS	5	Isometric projections	20
IV	PERSPECTIVE PROJECTIONS	4	Perspective projections	16
V	CROSS SECTION OF BUILDING COMPONENTS	3	Cross section of building components	15
VI	BUILDING DRAWING	6	Building drawing	10
	TOTAL	26		96

TEXT BOOK

1. K.R.Gopalakrishna “Fundamentals of Drawing” Subhas Publications, 2010.
2. K.R.Gopalakrishna “Engineering Drawing” (Vol. I & II), Subhas Publications, 2014.

REFERENCES

1. R.K. Dhawan, “A text book of Engineering Drawing”, S.ChandPublishers, Delhi, 2010.
2. G.S. Phull and H.S.Sandhu, “Engineering Graphics”, Wiley Publications, 2014.
3. K.Venugopal and V.Prabhu Raja, “Engineering Graphics”, New Age International Private Limited,2008.
4. M.B.Shah and B.C.Rana, “Engineering Drawing”, Pearson Education, 2005.
5. DhananjayA.Jolhe, “Engineering Drawing with an Introduction to AutoCAD”, Tata McGraw

Hill Publishing Company Limited, 2008.

6. Basant Agarwal and Agarwal.C.M., "Engineering Drawing", Tata McGraw Hill Publishing Company Limited, New Delhi, 2008.
7. IS 962 (1989) Code of practice for Architectural and Building Drawings

Model Question Paper

Code: **15CE22D**

II semester Diploma Examination **ENGINEERING DRAWING-II**

Time: 4 Hours][Max. Marks: 100

Note: Answer Any Three full questions from Part-A, Any 3 full Questions from Part B&Part C is compulsory.

Part –A(Any Two)

1. Draw the three principal views of the component as shown in the figure 1 10 marks

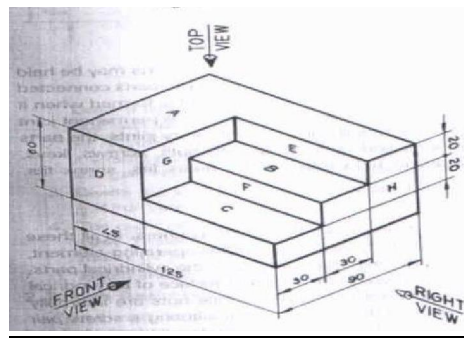

Fig-1

2. Draw the three principal views of the component as shown in the figure2

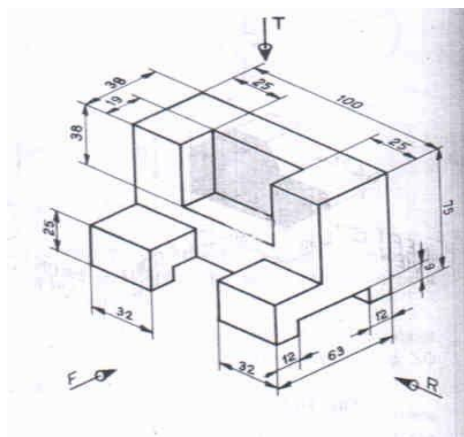

Fig.2

3. Show the conventional representation of Building materials in Section (IS: 962) 10 marks
(a) Brick Masonry (b) Stone Masonry (c) Steel works (d) Wood

PART-B(Any Three)

4. An equilateral triangular prism 30 mm side of base and 50mm long rests with one of its shorter edge on HP such that rectangular face containing the edge on which the prism rests is inclined at 30° to HP. The edge on which the prism rests is inclined at 60° to VP. Draw its projections.
15marks
5. A cylinder of 40mm diameter and axis height 60mm is resting with its ends of the base diameter on HP. The axis of the cylinder is inclined at 30° to the HP and appears to be inclined at 45° to VP. Draw the projections of the solid in its final position.
15marks

6. Draw the isometric view of the following objects whose orthographic views are given Fig 3
15 marks

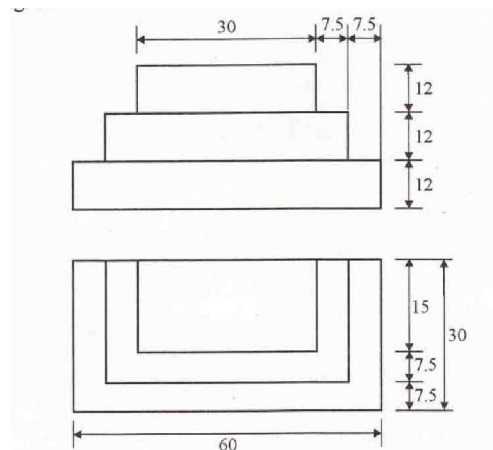

Fig-3

7. Draw the isometric view of the following objects whose orthographic views are given Fig 4

15marks

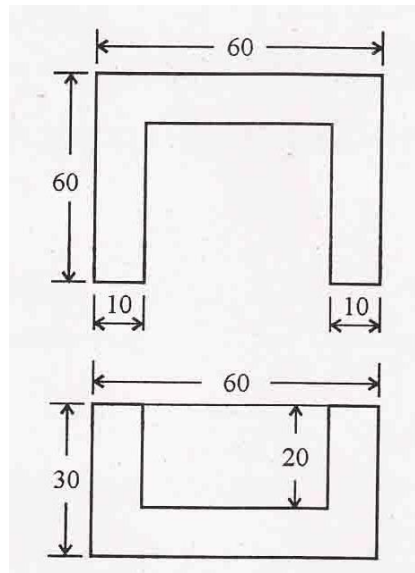

Fig-4

8. A Square based prism of 30mm side of base and height 50mm rests with its base on ground such that one of the rectangular faces is touching the picture plane. The station point lies on the center line of the object, 60mm aboveground and 50mm in front of the picture plane. Draw the perspective view of the square prism.
15 marks

PART- C(Compulsory)

9. The Line Diagram of a Two room building is shown in Fig 5. The Details and specification are as follows. 35 Marks

- (a) Level of Plinth above ground - 0.5m
- (b) Height of ceiling from the floor- 3m
- (c) Burnt Brick Masonry wall Thickness of wall 0.3m
- (d) Doors 1.0mX 2.1m
- (e) Windows 1.2mX1.2m
- (f) RCC Roof 0.15m thick
- (g) Parapet wall of Burnt Brick Masonry 1m height of 0.2m thick.
- (h) Provide suitable Foundation of Size Stone Masonry

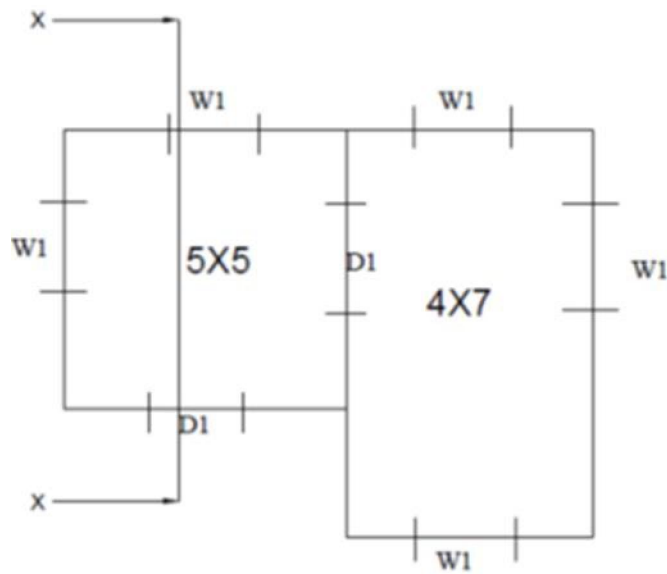

Draw to a scale of 1:50

- (i) Plan of the Building and 15Marks
- (ii) Front Elevation of the Building. 10Marks
- (iii) Section along xx 10 Marks

UNIT-I (15 Marks)

1. A hexagonal pyramid, base 30mm side and axis 60mm long has one of its triangular face containing the slant edge on which it rests are equally inclined to HP. The axis appears to be inclined at 45° to VP. Draw its projections when its base is nearer to the observer than its apex.
2. Draw the projection of a pentagonal prism of base side 25mm and axis length 45mm resting on a corner such that the two base edges passing through it make equal inclination with HP and its base inclined at 60° to HP and the axis appears to be inclined at 30° to VP in the top view.
3. An equilateral triangular prism 30 mm side of base and 50mm long rests with one of its shorter edge on HP such that rectangular face containing the edge on which the prism rests is inclined at 30° to HP. The edge on which the prism rests is inclined at 60° to VP. Draw its projections.
4. A cone of base diameter 50mm and altitude 70mm is lying with one of its generators on HP and the axis appears to be inclined to VP at an angle of 40° in the top view. Draw its top and front views.
5. A Hexagonal prism of 30 mm side of base and axis 60mm long is placed with one of its base edges on HP such that the axis is inclined at 35° to HP and 45° to VP. Draw its projections.
6. A Pentagonal pyramid 25mm side of base and 50mm altitude rests with one of its corners on HP such that the two base edges passing through the corner on which rests make equal inclinations with HP. The axis is inclined at 50° to VP and 30° to HP. Draw the top and front views of the pyramid.
7. A cone of base 60mm diameter and axis 80mm long rests on HP with its axis inclined 45° to HP and 30° to VP. Draw the top and front views of the cone.
8. Draw the top and front views of a right cylinder of base 50mm diameter and 70mm long when it lies on HP, such that its axis is inclined at 30° to HP and axis appears to be perpendicular to VP in the top view.
9. An equilateral triangular prism of base side 25mm and 50mm long rests with one of the its shorter edges on HP so that the rectangular face containing the edge on which the prism rests inclined at 30° to the HP. The edge on which the prism rests is inclined at 60° to the VP. Draw its projections.
10. A pentagonal prism of base edge 30mm and 60mm long has its base edge on HP. The axis of the prism is inclined at 30° to the HP and appears to be inclined at 45° to the VP. Draw the top view and the front views of the prism.
11. A hexagonal prism of 30mm base edge and axis 60mm long is placed with one of its base edges on HP so that the axis is inclined at 30° to HP and the axis appears to be inclined at 45° to VP. Draw the projections when the base of the prism is nearer to the observer.

12. A square prism of base edge 40mm and 60mm long rests with one of its corners of the base so that the longer edge passing through this corner is inclined at 40° to the HP. Draw the projections if the axis appears to be inclined at 45° to the VP in the top view.
13. A square pyramid of base edge 40mm and 60mm long has one of its shorter edges on HP. The axis of the pyramid is inclined at 30° to the HP and appears to be inclined at 45° to the VP. Draw the projections if the apex is near to the observer.
14. A cylinder of 40mm diameter and axis height 60mm is resting with its ends of the base diameter on HP. The axis of the cylinder is inclined at 30° to the HP and appears to be inclined at 45° to VP. Draw the projections.
15. A cone of base diameter 50mm and axis 80mm lies on HP with its axis inclined at 45° to HP and appears to be inclined at 30° to the VP in the top view. Draw the top and front views of the cone.
16. A right cylinder is 50mm diameter of base and height 70mm. It rests such that the axis is inclined at 30° and 45° to HP and VP respectively. Draw the top and front views.
17. A cone of base 80mm diameter and height 100mm is lying with one of its generators on HP and its axis appears to be inclined at 40° to VP in the top view. Draw its front and top views.
18. Draw the projections of a pentagonal prism 20mm side of base and axis 40mm long resting on a corner such that two base edges passing through it make equal inclinations with HP and its base is inclined at 60° to HP, and the axis appears to be inclined at 30° to VP in the top view.
19. Draw the top and front views of a rectangular pyramid of sides of base 20x25mm and height 35mm when it lies with one of its triangular faces containing the longer edge of the base on HP. This longer edge of the base containing the triangular face lying on HP is inclined at 60° to VP in the top view with the apex of the pyramid nearer to VP.
20. A pentagonal pyramid 20mm side of base of 35mm altitude rests with one of its corners on HP such that the two base edges passing through the corner on which it rests make equal inclinations with HP. The axis is inclined at 45° to VP and 30° to HP. Draw the top and front views of the pyramid.
21. A hexagonal pyramid, base 30mm side and axis 60mm long has one of its slant edges on HP such that two of its triangular faces containing the slant edge on which it rests are equally inclined to HP. The top view of the axis appears to be inclined at 45° to VP. Draw its projections when its base is nearer to the observer than its apex.
22. A cone of base 60mm diameter and axis 80mm long rests on HP with its axis inclined 45° and 30° with HP and VP respectively. Draw the top and front views of the cone.
23. Draw the top and front views of a right cylinder of base 45mm diameter and 60mm long when it lies on HP, such that its axis is inclined at 30° to HP and the axis appears to be perpendicular to the VP in the top view.

UNIT-2(10 MARKS)

1. Draw the three principal views of the component as shown in the figure.

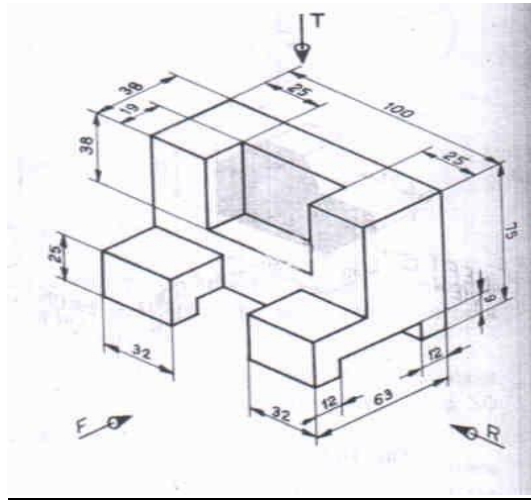

Fig-1

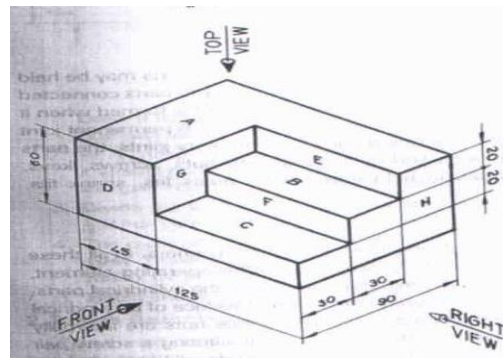

Fig-2

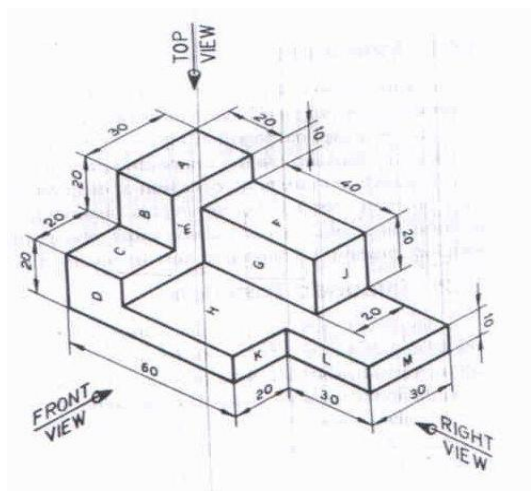

Fig-3

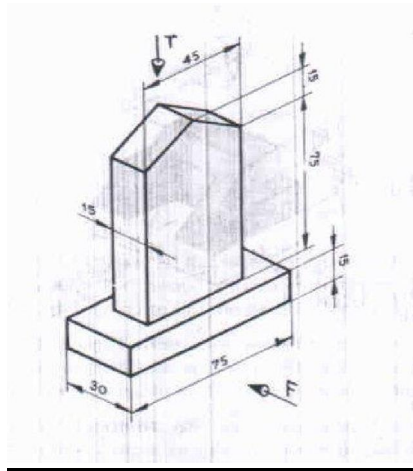

Fig-4

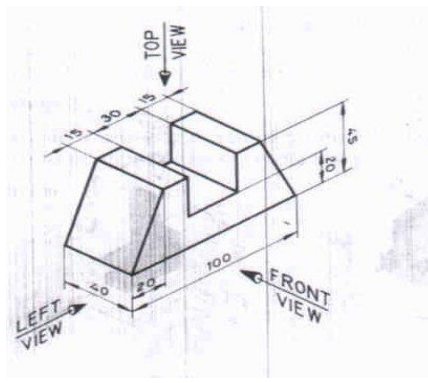

Fig-5

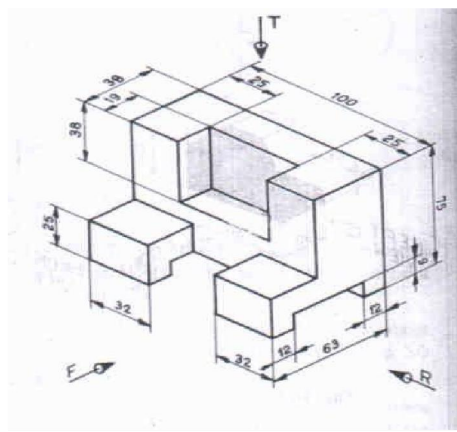
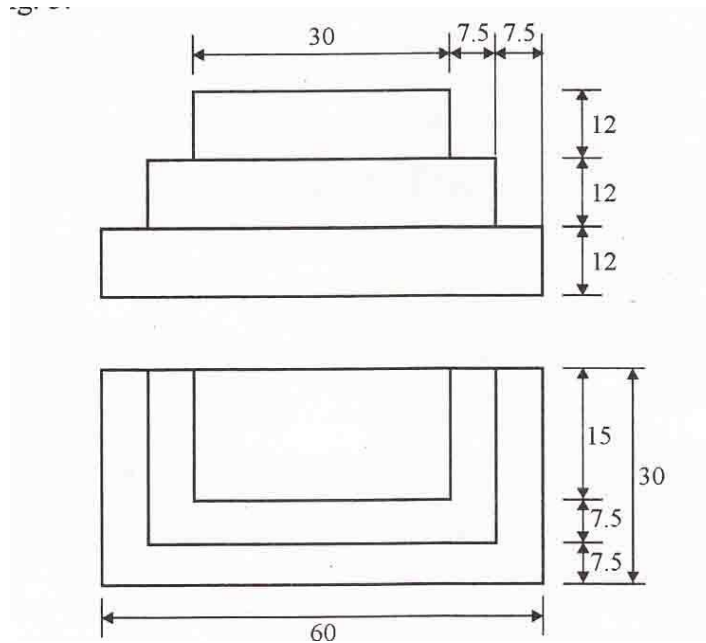

Fig-6

UNIT-3 (15 Marks)

1. Draw the isometric view of the following objects whose orthographic views are given below:



2. Draw the isometric view of the following objects whose orthographic views are given below:

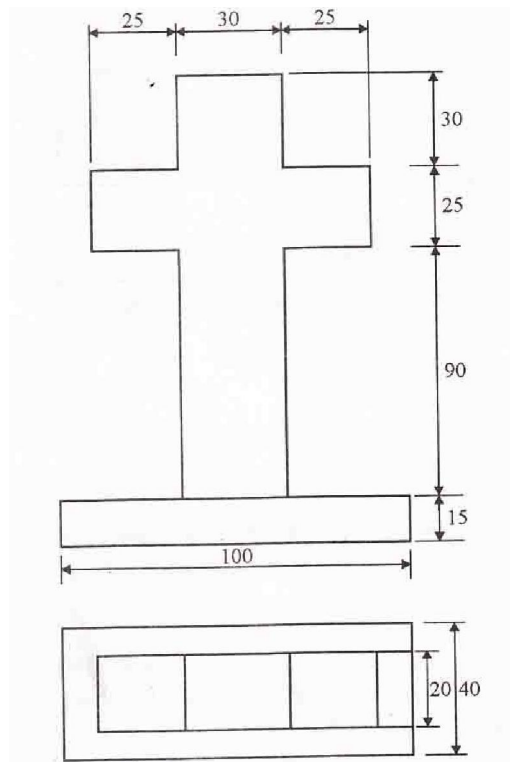

3. Draw the isometric view of the following objects whose orthographic views are given below:

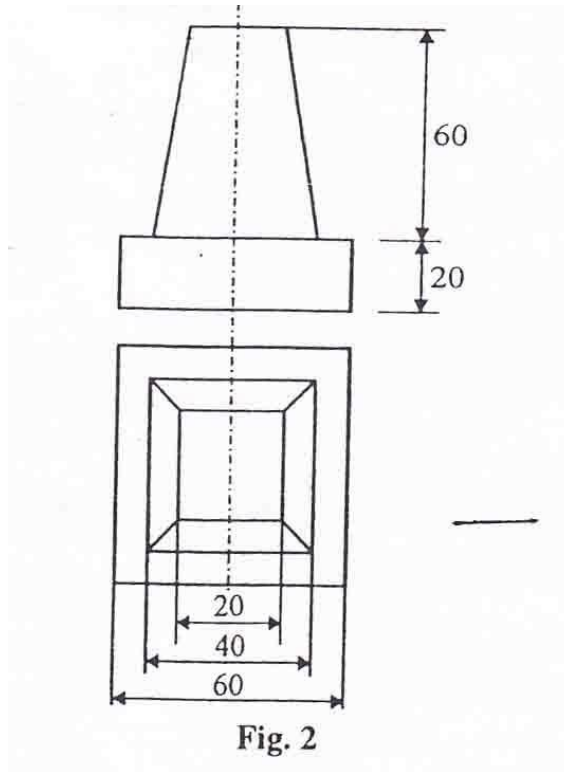

4. Draw the isometric view of the following objects whose orthographic views are given below:

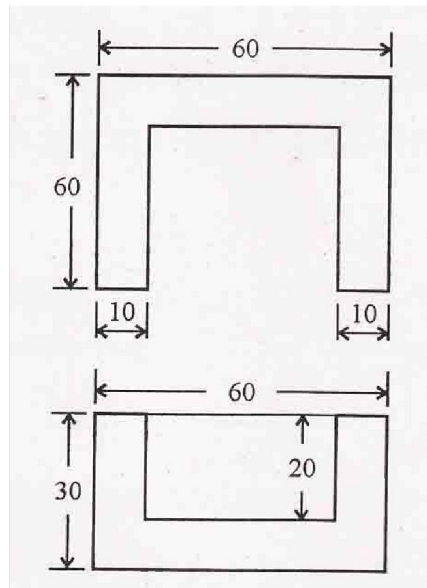

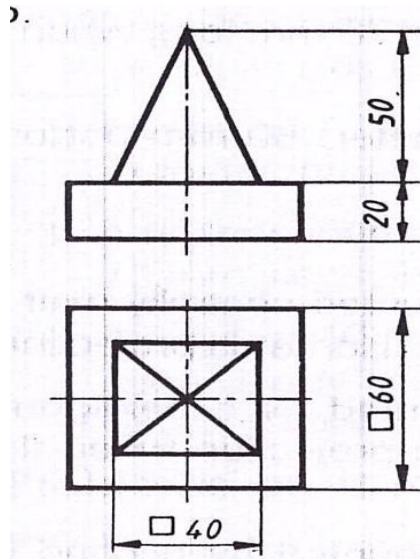

Fig-2

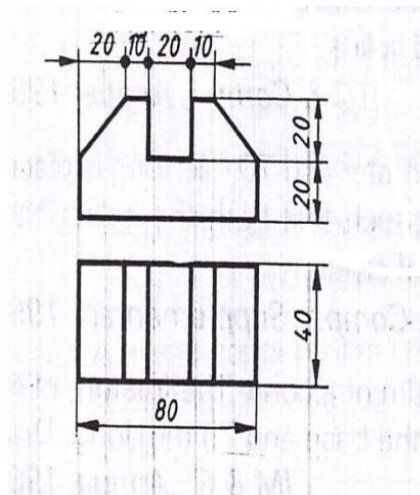

Fig-3

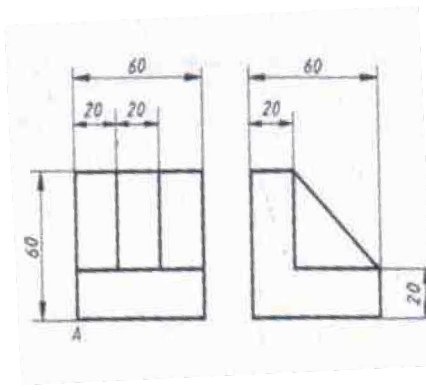

Fig-4

5. A Circular column of side 40mm and height 50mm is placed centrally on a square footing of side 100mm and thickness 25mm. Draw the Isometric projections of the combination
6. A Cube of side 50mm is resting coaxially over a circular slab of diameter 100mm and thickness 30mm. Draw the isometric view of the combination of the solid.

7. A cone having diameter of the base 60mm and height 70 mm is resting co- axially on the square slab of side 100mm and thickness 40mm. Draw the isometric view of the combination of the solid.
8. A cylinder of 50mm diameter and 50mm high is placed centrally on the rectangular footing of sides 75mm and 100mm and thickness 25mm. Draw the isometric projections of the arrangement.
9. A frustum of a cone 30mm top diameter and 60mm bottom diameter and 70mm long is placed vertically on a square block of 80mm side and 30mm thick such that both the solids have common axis. Draw the isometric of the combination of the solids.
10. A cylindrical slab 100mm diameter and 40mm thick is supporting a cube of 50mm edge. On the top of the cube rests a square pyramid of altitude 55mm and side of base 30mm such that the base edges of the pyramid are parallel to the edges of the top face. The axes of the solids are in the same straight line. Draw the isometric projection of the combination of the solids.
11. A square pyramid of base edge 50 mm and height 80 mm rests on the top of the cube of side 100 mm. Two sides of the base of the pyramid are parallel to the top edges of the cube. Draw the isometric view of the solid.
12. Three cubes of sides 60mm,40mm and 20mm are placed centrally one above the other. Draw the isometric projections of the combination.

UNIT-IV (15MARKS)

1. A Square based prism of 30mm side of base and height 50mm rests with its base and height 50mm rests with its base on ground such that one of the rectangular faces is touching the picture plane. The station point lies on the center line of the object, 60mm aboveground and 50mm in front of the picture plane. Draw the perspective view of the square prism.
2. A Cube of side 50mm side rests with its base on ground such that one of the square face is 20 mm behind the picture plane. The station point lies on the centerline of the object, 80mm above ground and 75mm in front of the picture plane.
3. A rectangular based pyramid of sides of base 30mm and 20mm, and height 35mm rests with its base edges in parallel to the picture plane and 30mm behind it. The station point is 50mm in front of the picture plane, 30mm to the left of the axis of the pyramid and 50mm above the ground. Draw the perspective view of the pyramid.
4. A model of steps has three steps of 15mm tread and rise 10mm. The steps measure 60mm widthwise. Draw the perspective view of the model when placed with its first step 25mm behind the picture plane and longer edge being parallel to it. The station point is 95mm from the picture plane, 60mm above ground and lies on the center line.
5. Draw one point parallel perspective view of the block shown below. The station point is located at 80mm to the right of the centre of the block and 100mm from the picture plane. The observers eyelevel is 60mm above the ground level.

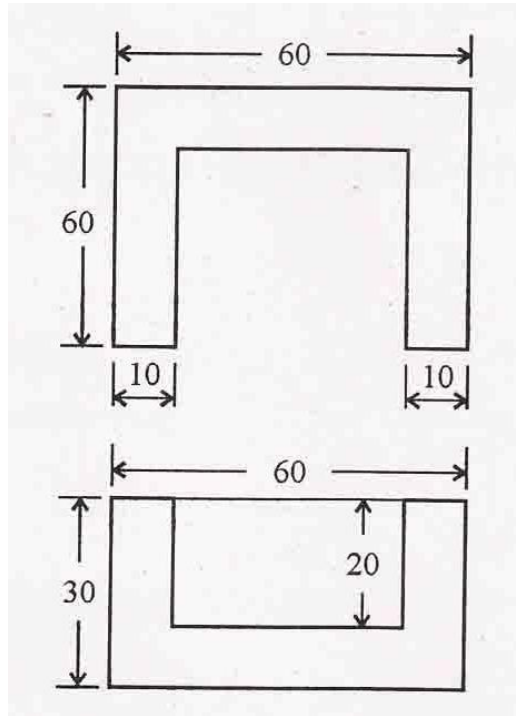

Fig-1

6. Draw the perspective view of a cube 25mm edge, resting on ground on one of its faces. It has one of its vertical edges in the picture plane and all its vertical faces are equally inclined to the picture plane. The station point is 55 mm in front of the picture plane. The station point is 55mm in front of the picture plane, 40mm above the ground and is in a central plane 9mm to the left of the centre of the cube.
7. A Square prism of 30mm side of base and height 40mm rests with its base on ground such that one of the rectangular faces is inclined at 30° to the picture plane. The nearest vertical edge touches the picture plane. The station point is 45mm in front of the picture plane, 65mm above ground and lies opposite to the nearest vertical edge that touches the picture plane. Draw the perspective view.
8. A cube of 45mm side of base rests on ground such that one of the square face is inclined at 25° to the picture plane. The nearest vertical edge touches the picture plane. The station point is 65mm in front of the picture plane, 85mm above ground and lies opposite to the nearest vertical edge that touches the picture plane. Draw the perspective view.
9. Draw one point perspective view of the block shown below. The station point is located at 80mm to the right of the centre of the block and 100mm from the picture plane. The observers eye level is 60mm above the ground level.

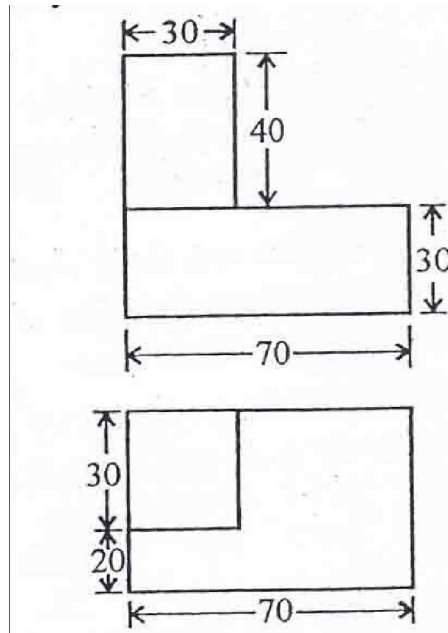

Fig-2

10. Draw the two point perspective view of the model shown in fig3 when its right touches picture plane and its longer side makes an angle of 30° with it. The station point is 100 mm in front of the picture plane and exactly opposite to the vertical edge touching the picture plane and the point of the sight is 120mm above the ground.

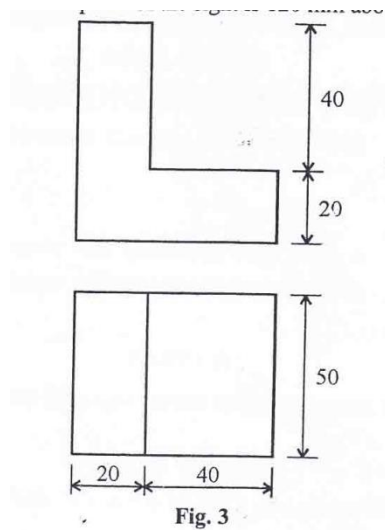

Fig. 3

UNIT-V (10 Marks)

1. Show the conventional representation of Building materials in Section (IS: 962)
2. Draw the cross section of wall from foundation to parapet for the given details.

UNIT-VI (35 Marks)

1. The Line Diagram of a Single room building is shown in Fig 1. The Details and specification are as follows.
- Level of Plinth above ground - 0.5m
 - Height of ceiling from the floor- 3m
 - Burnt Brick Masonry wall Thickness of wall-0.3m
 - Doors 1.0mX 2.1m
 - Windows 1.2mX1.2m
 - RCC Roof 0.15m thick
 - Parapet wall of Burnt Brick Masonry 1m height of 0.2m thick.
 - Provide suitable Foundation of Size Stone Masonary

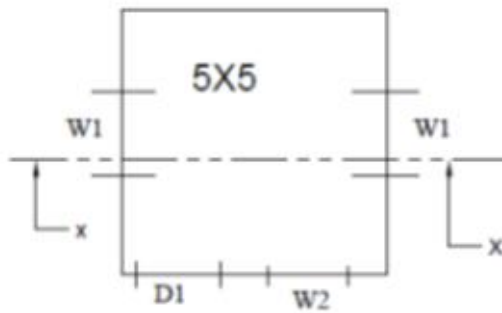

All Dimensions in Metre

Draw to a scale of 1:50

- Plan of the Building and
 - Front Elevation of the Building.
 - Section along xx
2. The Line Diagram of a two room building is shown in Fig 2. The Details and specification are as follows.
- Level of Plinth above ground - 0.5m
 - Height of ceiling from the floor- 3m
 - Burnt Brick Masonry wall Thickness of wall- 0.3m
 - Doors 1.0mX 2.1m
 - Windows 1.2mX1.2m
 - RCC Roof 0.15m thick
 - Parapet wall of Burnt Brick Masonry 1m height of 0.2m thick.
 - Provide suitable Foundation of Size Stone Masonary

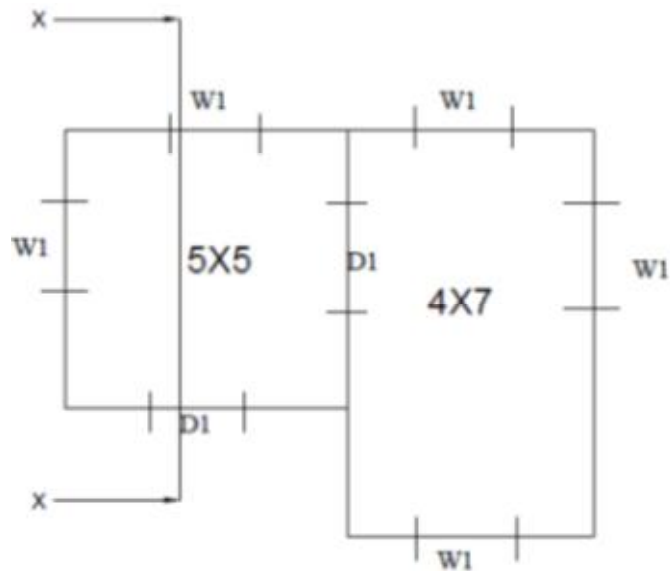

All Dimensions in metre.

Draw to a scale of 1:50

- (i) Plan of the Building and
- (ii) Front Elevation of the Building.
- (iii) Section along xx