

Government of Karnataka
Department of Technical Education
Board of Technical Examinations, Bengaluru

	Course Title: <u>ENGINEERING DRAWING</u>	Course Code: <u>15ME01D</u>
	Semester : <u>I / II</u>	Core/ Elective: <u>Core</u>
	Teaching Scheme (L:T:P) : <u>0:2:4</u>	Credits: <u>3 Credits</u>
	Type of course: <u>Lectures & Practice</u>	Total Contact Hours: <u>78</u>
	CIE: <u>25 Marks</u>	SEE: <u>100 Marks</u>

**(Common to E&E /MECHATRONICS/ HPT/ WSM/TEXTILE
 /MINING/CERAMICS/AGRICULTURE ENGG./ AERONAUTICAL ENGG./LEATHER & FASHION
 TECHNOLOGY Programmes)**

Pre-requisites : Zeal to learn the subject.

Course Objectives :

1. The course is aimed at developing Basic Graphic skills.
2. Develop Skills In Preparation Of Basic Drawings.
3. Skills in Reading and Interpretation of Engineering Drawings.

Course Outcomes:

On successful completion of the course, the students will be able to attain CO:

Course Outcome		CL	Linked units	Linked PO	Teaching Hrs
CO1	Usage of the drawing instruments effectively by students	<i>R/U/A</i>	1	1,2,3,9,10	15
CO2	Interpret and draw the basic engineering drawing skills related to projections of points, straight lines, planes and solids.	<i>R/U/A</i>	2,3,4	1,2,3,9,10	42
CO3	Draw Orthographic and Isometric views of simple Machine components.	<i>U/A</i>	5,6	1,2,3,9,10	21
Total sessions					78

COURSE-PO ATTAINMENT MATRIX

Course	Programme Outcomes									
	1	2	3	4	5	6	7	8	9	10
ENGINEERING DRAWING	3	3	3	-	-	-	-	-	3	3

Level 3- Highly Addressed, Level 2-Moderately Addressed, Level 1-Low Addressed.

Method is to relate the level of PO with the number of hours devoted to the COs which address the given PO.
 If $\geq 40\%$ of classroom sessions addressing a particular PO, it is considered that PO is addressed at Level 3
 If 25 to 40% of classroom sessions addressing a particular PO, it is considered that PO is addressed at Level 2
 If 5 to 25% of classroom sessions addressing a particular PO, it is considered that PO is addressed at Level 1
 If $< 5\%$ of classroom sessions addressing a particular PO, it is considered that PO is considered not-addressed.

COURSE CONTENT AND BLUE PRINT OF MARKS FOR SEE

Unit No	Unit Name	Hour	Questions to be set for SEE/MARKS			Marks weightage	weightage (%)
			R	U	A		
1	DIMENSIONING	15	--	10	20	30	20
2	PROJECTION OF POINTS AND LINES	15	--	10	20	30	20
3	PROJECTION OF PLANE SURFACES	12	--	--	20	20	15
4	PROJECTION OF SOLIDS	15	---	---	20	20	15
5	CONVERSION OF PICTORIAL VIEWS INTO ORTHOGRAPHIC VIEWS	10	---	---	15	15	10
6	ISOMETRIC PROJECTIONS	12	---	---	30	30	20
Total				20	125	145	100

Legend: R; Remember, U: Understand A: Application

COURSE CONTENT

UNIT:I	DIMENSIONING	CONTACT HOURS: 15 Hours
---------------	---------------------	--------------------------------

Introduction to Engineering Drawing-Drawing Instruments – Standard Sizes of Drawing sheets and layout of drawing sheets-Types of lines and their applications-Conventions for various materials-Introduction to Dimensioning-Elements of Dimensioning –Systems of Dimensioning-Methods of arrangements of Dimensioning- Dimensioning of common features like diameters, radii, arc and chords.

UNIT:II	PROJECTION OF POINTS AND LINES	CONTACT HOURS: 15 Hours
----------------	---------------------------------------	--------------------------------

Introduction to orthographic projection- Planes of projection- Four Quadrants- Concept of first & third angle projection method- Projection of points in all the four quadrants.
 Projection of lines – Parallel to both HP and VP - parallel to one plane and Perpendicular to other- parallel to one plane and Inclined to the other.
(First angle projection should be followed).

UNIT:III	PROJECTION OF PLANE SURFACES	CONTACT HOURS: 12 Hours
-----------------	-------------------------------------	--------------------------------

Construction of polygons-Projection of plane Surfaces–Planes parallel to one plane and Perpendicular to other two - Planes Perpendicular to one plane and inclined to the other.

UNIT:IV	PROJECTION OF SOLIDS	CONTACT HOURS: 15 Hours
----------------	-----------------------------	--------------------------------

Positioning of solids – lying with base on HP-Base or Axis inclined to HP-lying one of their lateral faces on HP- lying one of their lateral edges on HP.

UNIT:V	CONVERSION OF PICTORIAL VIEWS INTO ORTHOGRAPHIC VIEWS	CONTACT HOURS:09 Hours
---------------	--	-------------------------------

Introduction –Guidelines for Conversion of pictorial views into Orthographic Views

UNIT:VI	ISOMETRIC PROJECTIONS	CONTACT HOURS: 12 Hours
----------------	------------------------------	--------------------------------

Principles of isometric projection – isometric scale – isometric views of simple solids – cube, prisms, pyramids, cylinder and cone - Conversion of orthographic views into isometric View of Simple M/C Components.

TOTAL: 78 Hours

TEXT BOOK

1. K.R.Gopalakrishna“*Fundamentals of Drawing*”Subhas Publications, 2010.
2. K.R.Gopalakrishna“*Engineering Drawing*” (Vol. I & II), Subhas Publications, 2014.

REFERENCES

1. BasantAgarwal and Agarwal.C.M., “*Engineering Drawing*”, McGraw Hill Publishing Company Limited, New Delhi, 2012
2. DhananjayA.Jolhe, “*Engineering Drawing with an Introduction to AutoCAD*”,McGrawHill Publishing Company Ltd., 2008.
3. P.I.Varghese,“*Engineering Graphics*” ,McGrawHill Publishing Company Ltd. 2013.
4. R.K. Dhawan, “*A text book of Engineering Drawing*”,S.ChandPublishers, Delhi,2010.
5. G.S. Phull and H.S.Sandhu, “*Engineering Graphics*”,Wiley Publications, 2014.
6. K.Venugopal and V.Prabhu Raja, “*Engineering Graphics*”, New Age International PrivateLimited, 2008.
7. M.B.Shah and B.C.Rana, “*Engineering Drawing*”, Pearson Education, 2005

Course Assessment and Evaluation Scheme:

Method	What		To whom	When/Where (Frequency in the course)	Max Marks	Evidence collected	Course outcomes
Direct Assessment	*CIE	IA	Students	Graded Exercises (Average marks allotted for each graded exercise)	25	Drawing Sheets	1,2,3
	*SEE	End Exam		End of the course	100	Answer scripts at BTE	1,2,3
Indirect Assessment	Student Feedback on course		Students	Middle of the course		Feedback forms	1, 2,3 Delivery of course
	End of Course Survey			End of the course		Questionnaires	1,2,3 Effectiveness of Delivery of instructions & Assessment Methods

*CIE – Continuous Internal Evaluation *SEE – Semester End Examination

NOTE: THIS SUBJECT SHOULD BE THOUGHT IN A BATCH OF 15 TO 20 STUDENTS, TEACHER ALLOTTED PER BATCH HAS TO MONITOR, EVALUATE OR ASSESS THE STUDENTS.

MODEL QUESTION PAPER

Code:15ME01D

First / Second Semester Diploma Examination
ENGINEERING DRAWING(Conventional)

(Common to E & E / MECHATRONICS/ HPT/ WSM / TEXTILE Programmes)

Time; 4 Hours]

[Max. Marks: 100

Note: i) **Part –A** is compulsory.

ii) Answer any **FIVE** questions from **Part-B** and **TWO** questions from **Part-C**.

PART –A

1. List the standard sizes of the drawing sheets. 05
2. Mention the types of lines and their applications. 05
3. Draw the projections of the following points: 2 x 5=10
 - a) Point P is 25mm above the HP and 40mm behind the VP
 - b) Point Q is 30mm below the HP and 40mm behind the VP

PART –B

4. Copy the given sketch to 1: 1 scale and dimension it adopting aligned system with chain dimensioning.
5. Illustrate the dimensioning of the given common features: diameters, radii, arcs and chords. 10
6. A line 70 mm long inclined at 30° to HP and parallel to VP. The line is 80 mm in front of VP. The lower end is 35 mm in front of HP and 110 mm in front of right PP and is away from it than the higher end. Draw the three views of the line. 10
7. A line 80 mm long is inclined at 45° to VP and parallel to HP. The end nearer to VP is 30 mm in front of VP, 60 mm above HP and 100 mm in front of right PP. Draw the three views of the line. 10
8. A regular pentagonal lamina of 30 mm side rests on HP with one of its edge perpendicular To VP. The surface of the lamina is inclined at an angle of 45° to HP. Draw its Top and front views. 10
9. A circular lamina 60 mm diameter rests on HP such that the surface of the lamina is Inclined at 30° to HP. Draw its Top and front views. 10
10. A hexagonal pyramid 25 mm side of base and height 60 mm rests with one of its base edges on HP such that the base is inclined at 45° to HP and the axis is parallel to VP. Draw its Top and front views. 10
11. Draw the top and front views of a cone 60 mm diameter base and axis 80 mm long lying on HP with its axis inclined at 45° to it parallel to VP. Draw its Top and front views 10

PART –C

12. Draw the isometric view of the machine component whose orthographic views are given below: 15

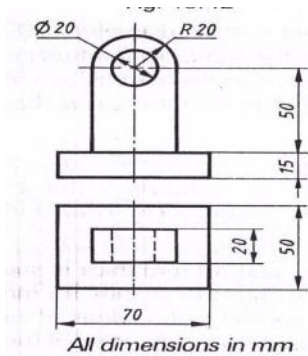

13. Draw the three principal views of the component as shown in the figure. 15

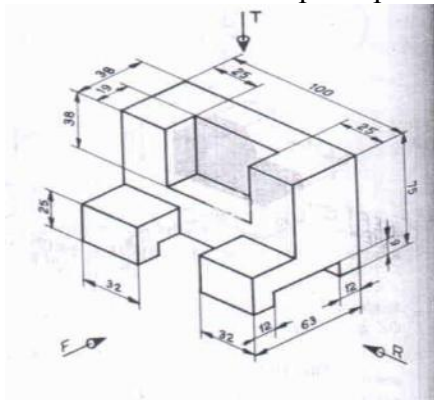

14. Draw the isometric projection of a frustum of a cone of 40 mm top diameter, and 80 mm bottom diameter and 60 mm height. 15

MODEL QUESTION BANK

First /Second Semester Diploma Examination

Course: **ENGINEERING DRAWING Code: 15ME01D**

(Common to MECHATRONICS/ HPT/E&E/WSM/TEXTTILE Programmes)

CO 1:USAGE OF THE DRAWING INSTRUMENTS EFFECTIVELY BY STUDENTS

LEVEL: UNDERSTANDING

1. List the standard sizes of drawing sheets.
2. Mention the types of lines and their applications.
3. Illustrate the elements of dimensioning with the help of a sketch.
4. Illustrate the dimensioning of given common features: diameter, radius, chord, Arc and angle.
5. Mention the uses of the following drawing instruments.
 - i) T-square ii) Set square iii) Bow compass iv) Clinograph v) Minidrafter
6. Mention the uses of the following drawing instruments.
 - i) French curves ii) Protractor iii) Clips iv) Erasing Shield v) Drafting machine

LEVEL: APPLICATION

7. Draw the standard layout of aA2 size drawing sheet
8. Copy the given sketch to 1:1 scale and dimension adopting aligned system with parallel dimensioning method.

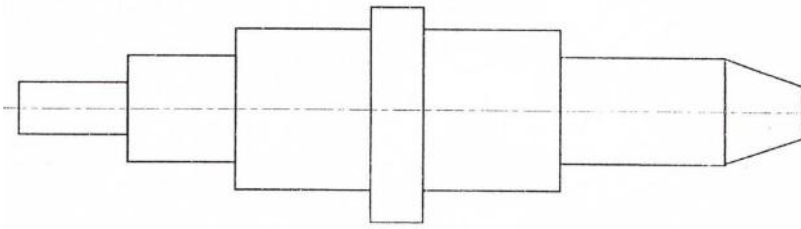

9. Copy the given sketch to 1:1 scale and dimension adopting aligned system with progressive dimensioning method.

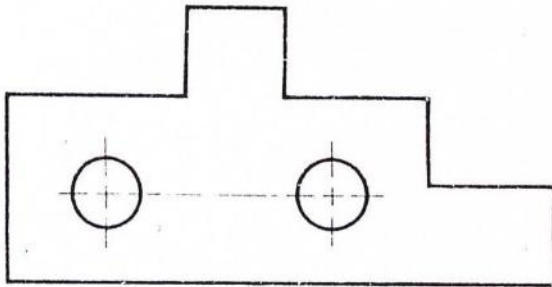

10. Copy the given sketch to 1:1 scale and dimension adopting unidirectional system with chain dimensioning method.

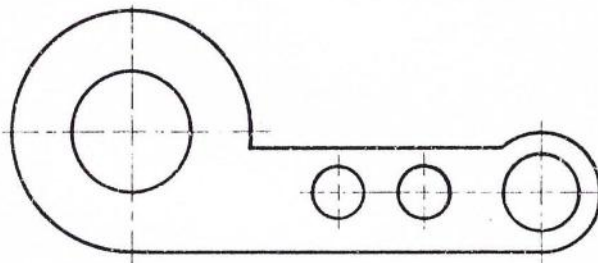

11. Copy the given sketch to 1:1 scale and dimension adopting unidirectional system with combined dimensioning method.

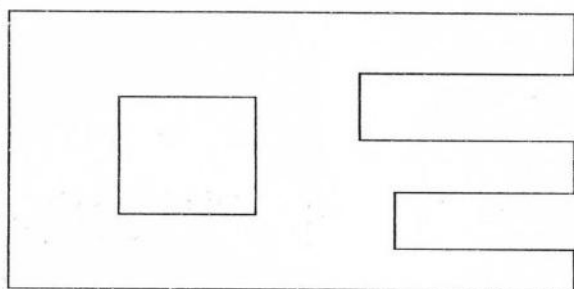

12. Copy the given sketch to 1:1 scale and dimension adopting unidirectional system with parallel dimensioning method.

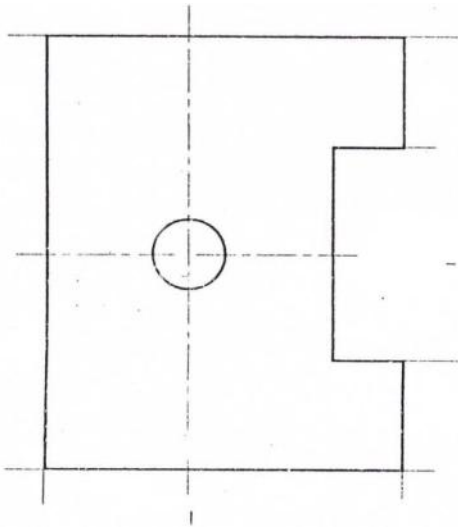

13. Copy the given sketch to 1:1 scale and dimension adopting aligned system with chain dimensioning method.

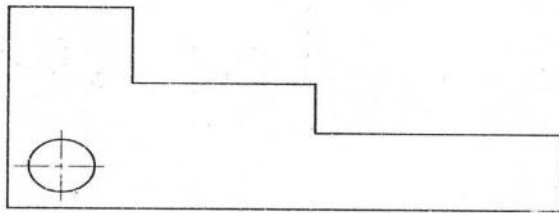

CO 2: INTERPRET AND DRAW THE BASIC ENGINEERING DRAWING SKILLS RELATED TO PROJECTIONS OF POINTS.

LEVEL: UNDERSTANDING

1. Draw the symbolic representation of First angle projection method.
2. Draw the symbolic representation of Third angle projection method.

LEVEL: APPLICATION

3. A point P is 40 mm in front of VP, 50 mm above HP and 30 mm in front of left PP. Draw the three principal views of the point.
4. A point P is 30 mm above HP, 50 mm behind VP and 45 mm in front of left PP. Draw the three principal views of the point
5. Draw the three principal views of a point P lying 40 mm behind VP, 60 mm below HP and 30 mm behind the right PP
6. Draw the three principal views of a point P lying 60 mm below HP, 50 mm in front of VP and 45 mm in front of the left PP.

(10Marks Questions)

1. Draw the projections of the following points:
 - i) P is 25mm below the HP and in the VP
 - ii) Q is 40mm behind the VP and in the HP
 - iii) R is 30mm below the HP and 30mm in front of the VP
 - iv) S is 25mm above the HP and 25mm behind the VP
2. Draw the projections of the following points:
 - i) T is 25mm above the HP and 30mm in front of the VP.
 - ii) U is in both the VP and HP
 - iii) V is 35mm below the HP and 30mm behind the VP
 - iv) W is 30mm above the HP and 35mm behind the VP
3. Draw the projections of the following points:
 - i) A is 25mm above the HP and 35mm in front of the VP
 - ii) B is 25mm above the HP and 40mm behind the VP
 - iii) C is 30mm below the HP and 40mm behind the VP
 - iv) D is 30mm below the HP and 35mm in front of the VP
4. Draw the projections of the following points:
 - i) E is 25mm above the HP and in the VP.
 - ii) F is 30mm below the HP and in the VP
 - iii) G is 35mm in front of the VP and in the HP
 - iv) H is 40mm behind the VP and in the HP
5. Draw the three principal views of a line 80 mm long placed parallel to VP and perpendicular to HP. The line is 70mm in front of VP and 60mm in front of right PP. The lower end of the line is 30mm above HP.
6. Draw the three principal views of a line 80 mm long when it is placed parallel to both HP & VP. One of the ends of the line is 70 mm above HP, 60 mm in front of VP and 30mm in front of the right PP.
7. A line AB 80 mm long is inclined at 30° to HP and parallel to VP. The line is 90 mm in front of VP. The lower end A is 35 mm above HP, 110 mm in front of the right PP and is away from it than the higher end. Draw the three principal views of the line.
8. A line AB 80 mm long is inclined at 45° to VP and parallel to HP. The end nearer to VP is 30mm in front of VP, 60 mm above HP and 100 mm in front of right PP. Draw the three principal views of the line.
9. Draw the projections of a line AB, 80 mm long inclined at 30° to HP and parallel to VP. The line is 40 mm in front of VP. The lower end A is 20 mm above HP.
10. The length of a line is 100 mm long and is inclined at 45° to VP and parallel to HP. The line is 15 mm above HP and one end of the line is 10 mm in front of VP. Draw the projections of the line and measure top and front views.
11. The length of top view of a line which is parallel to VP and inclined at 45° to HP is 50 mm. One end of the line is 12 mm above HP and 25 mm in front of 45° to VP. Draw the projections of the line and determine its true length.
12. Draw the projections of a line 70 mm long lying in VP and inclined at 45° to HP. The lower end of the line is 10 mm above HP

**CO 2: INTERPRET AND DRAW THE BASIC ENGINEERING DRAWING SKILLS
RELATED TO PROJECTIONS OF STRAIGHT LINES**

LEVEL: APPLICATION

(10 MARKS QUESTIONS)

1. An equilateral triangular lamina of side 40mm rests with one its sides on HP so that the surface of the lamina is inclined at 30° to HP. Draw the projections of the lamina.
2. An equilateral triangular lamina of sides 30mm is resting with one of its corners on HP, The surface of the lamina is inclined at 45° to HP. which the lamina rests is inclined at Draw the projections of the lamina.
3. A square lamina of 40mm side rests with one of its sides on HP so that the surface of the lamina is inclined at 30° to HP. Draw the top and front views of the square lamina in this position.
4. A square lamina of 40mm sides rests with one of its corner on HP. The diagonal passing through this corner is inclined at 45° to HP .Draw its projections.
5. A square lamina of side 40mm rests with one of its corner on HP. The diagonal passing through this corner is inclined at 45° to HP .Draw its projections.
6. A regular pentagonal lamina has its sides as 30mm. It is resting with one of its corners on HP. The plane surface of the lamina is inclined at 30° to HP. Draw its projections
7. A hexagonal lamina of sides 30mm rests on one of its sides on HP so that the surface of the lamina is inclined at 45° to HP. Draw the top and front views of the lamina.
8. A hexagonal lamina of side 30mm is resting with one of its corner on HP so that the diagonal passing through that corner is inclined at an angle of 45° to HP. Draw the top and front views of the lamina.
9. A pentagonal plane lamina of edges 20mm is resting on HP with one of its corner touching it such that plane surface makes an angle of 60° with HP. to this corner makes Draw the top and front views of the plane lamina in this position.
10. A hexagonal lamina of 30mm sides rests on HP on one of its sides. The side which is on HP is perpendicular to VP and the surface of the lamina is inclined to HP at 45° . Draw the front view and the top view of the lamina.
11. A circular lamina of 60mm diameter rests on HP such that the surface of the lamina is inclined at 30° to HP. Obtain its projections
12. A Circular plane of diameter 50mm has its surface parallel to HP and perpendicular to VP. Its Centre is 20mm above HP and 30mm in front of VP. Draw its projections.
13. A Pentagonal lamina of side 30mm is placed with one side on HP and the surface inclined at 50° to HP and perpendicular to VP. Draw its projections.
14. A Hexagonal plane of side 30mm is placed with a side on VP and the surface inclined at 45° to VP and perpendicular to HP. Draw its projections.

**CO 2: INTERPRET AND DRAW THE BASIC ENGINEERING DRAWING SKILLS
RELATED TO PROJECTIONS OF SOLIDS.**

LEVEL: APPLICATION

(10Marks Questions)

1. A triangular prism of base edge 40mm and height 65mm rests with one of its base edges on HP so that the axis of the prism is inclined at 30° with HP. Draw the projections when the axis of the prism is parallel to VP.
2. A square prism of base edge 40mm and height 65mm rests with one of its base edges on HP. The axis of the prism is inclined at 45° to HP and parallel to VP. Draw the top and the front views of the prism.
3. A pentagonal prism of base 35mm and height 60mm has its base edge on HP. Draw the projections if the base of the prism is inclined at 30° to the HP. The axis of the prism is parallel to the VP.
4. A Hexagonal prism of base 35mm and height 60mm is resting with its base edge on HP so that the axis is inclined at 45° and parallel to VP. Draw its projections.
5. The axis of the square prism of base edge 40mm and height 60mm is inclined at 30° to HP and parallel to the VP. Draw the projections when the prism is placed with one of its corners on HP. The two adjacent base edges containing this corner are equally inclined to HP.
6. A pentagonal prism of base 35mm and axis height 60mm is resting with one of its base corners on HP such that the axis is inclined at 30° to the HP. Draw the projections when the axis of the prism is parallel to VP.
7. A triangular pyramid of base edge 40mm and height 65mm is resting with one of its base edges on HP so that the axis of the pyramid is parallel to VP and inclined at 45° to HP. Draw the projections.
8. Draw the projections of a hexagonal pyramid resting with one of its base edges on HP such that the axis of the pyramid is inclined at 30° to HP. The hexagonal pyramid has its base edges as 35mm and axis height as 60mm.
9. A pentagonal pyramid of base edge 35mm and axis height 65mm rests with one of its base corners on HP so that the axis of the pyramid is inclined at 45° to the HP. Draw the projections if the axis of the pyramid is parallel to the VP.
10. A square pyramid of base 40mm and axis height 65mm rests with its triangular lateral surfaces on HP so that the axis of the pyramid is parallel to the VP. Draw the projections.
11. A hexagonal pyramid is resting with one of its triangular lateral surfaces on HP. Draw the projections if its base edges are 40mm and the axis height is 65mm.
12. A pentagonal pyramid of base edge 40mm and axis 65mm rests with its slant edge on HP so that its axis is parallel to the VP. Draw the projections.
13. A cylinder of 40mm diameter and axis height 65mm rests with its points of the circumference on HP so that the axis is inclined at 45° to the HP and parallel to the VP. Draw the projections.

14. A cone of 40mm diameter and axis height 65mm is resting with points of the circumference on HP. Draw the projections if the axis of the cone is inclined at 30° with HP and parallel to VP.
15. A cone of 45mm diameter and axis height 60mm is resting with its end slant generator on HP so that the axis of the cone is parallel to VP. Draw the projections of the cone.
16. A pentagonal prism of 30mm side of base and height 60mm rests with one of its edges of the base on HP such that the axis is inclined at 30° to HP and parallel to VP. Draw the top and front views.
17. A hexagonal pyramid of 25mm side of base and height 60mm rests with one of its base edges on HP such that the base is inclined at 45° to HP, and the axis parallel to VP. Draw the top and front views.
18. A hexagonal pyramid of 25mm edge of base and height 60mm rests with one of its corners of the base on HP such that the base is inclined at 30° to it and the axis parallel to VP. The two of the base edges containing the corner on which the pyramid rests make equal inclinations with HP. Draw the projections.
19. A pentagonal prism of 30mm side of base and height 55mm rests with one of its rectangular faces on HP and the axis parallel to VP. Draw its projections.
20. Draw the top and front views of a triangular prism of 35mm side of triangular faces and height 60mm rest with one of its longer edges on HP such that the axis is parallel to VP and the rectangular face opposite to the slant edge on which the prism rests in perpendicular to VP.
21. Draw the top and front views of a pentagonal pyramid of side of base 30mm and height 60mm rests with one of its slant edges on HP and the axis parallel to VP.

CO 3: DRAW ORTHOGRAPHIC VIEWS OF SIMPLE MACHINE COMPONENTS.

LEVEL: APPLICATION

(15 MARKS QUESTION)

Draw the three principal views of the component as shown in the figure.

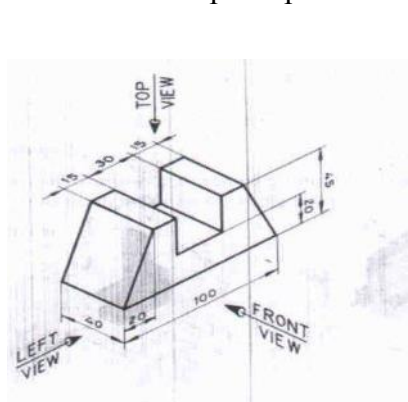

FIG-1

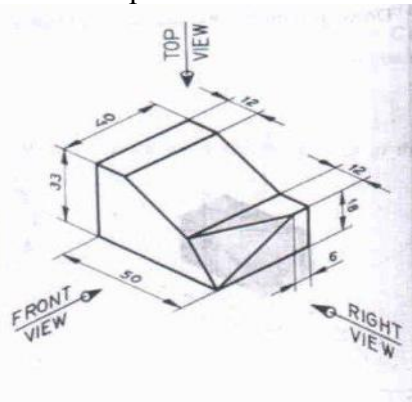

FIG-2

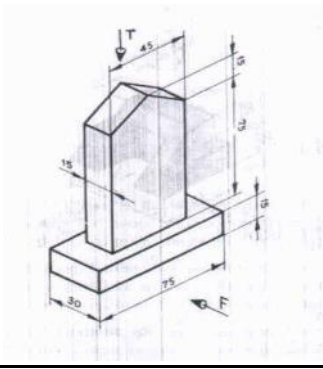

FIG-3

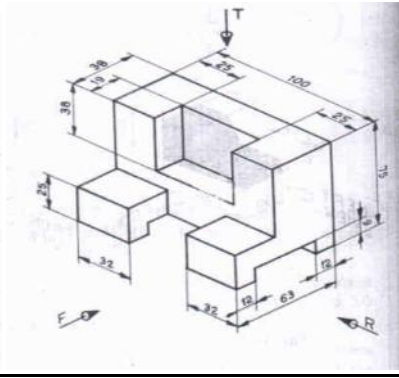

FIG-4

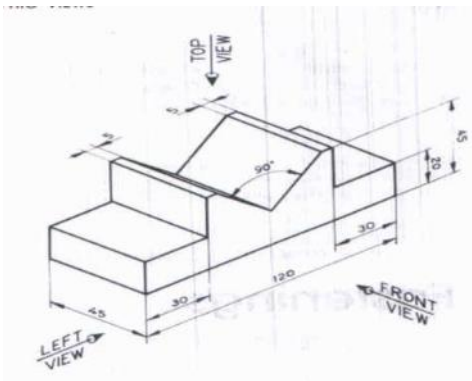

FIG-5

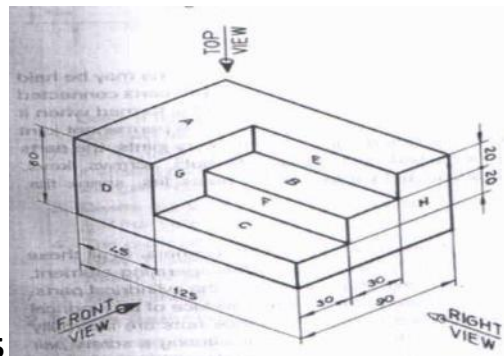

FIG-6

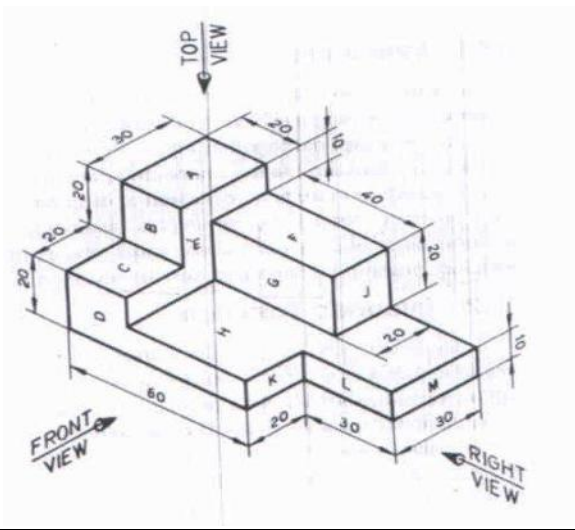

FIG-7

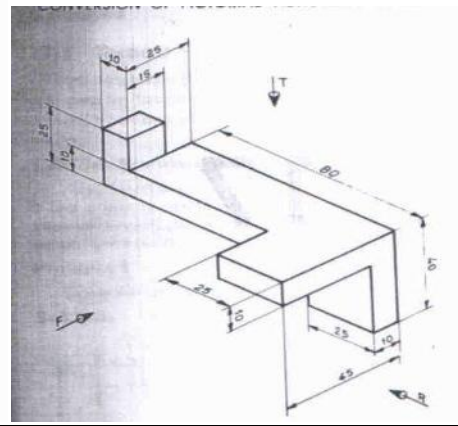

FIG-8

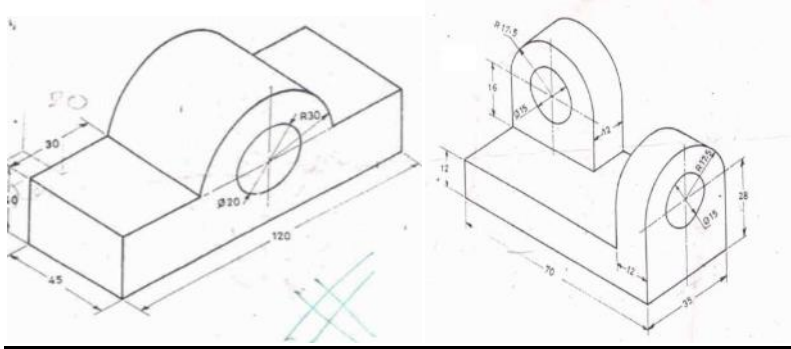

FIG-9 FIG-10

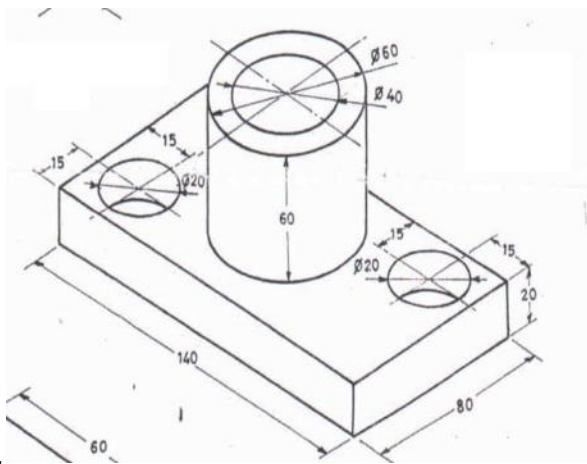

FIG-11

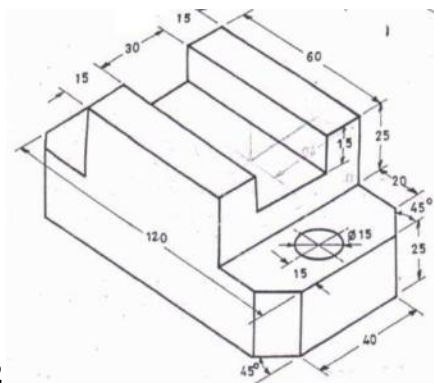

FIG-12

ALL DIMENSIONS ARE IN MM

CO 3: DRAW ISOMETRIC VIEWS OF SIMPLE MACHINE COMPONENTS.

LEVEL: APPLICATION

(15 MARKS QUESTION)

.Draw the isometric view of the machine component whose orthographic views are given below:

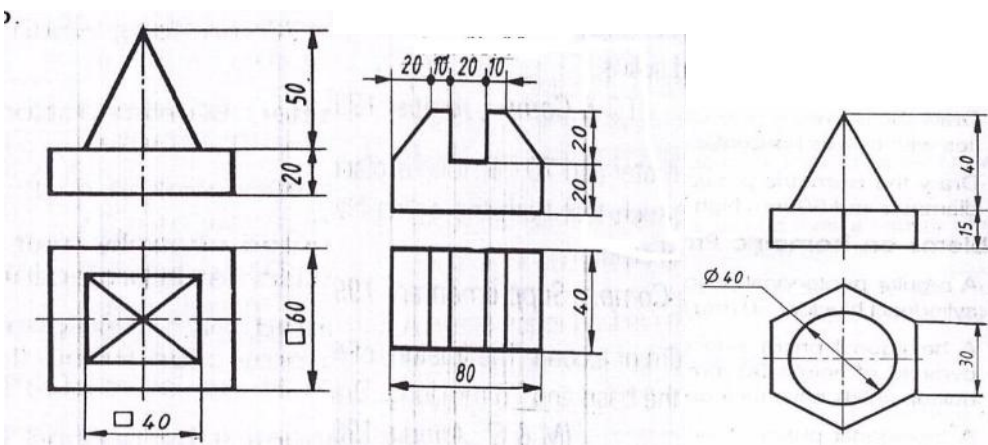

FIG-1

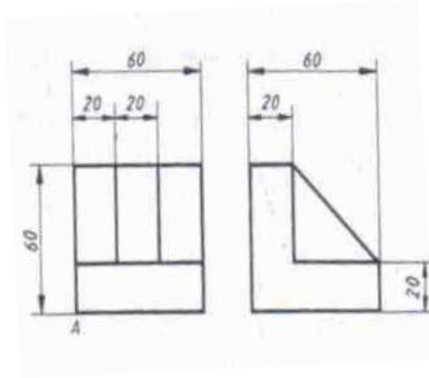

FIG-2

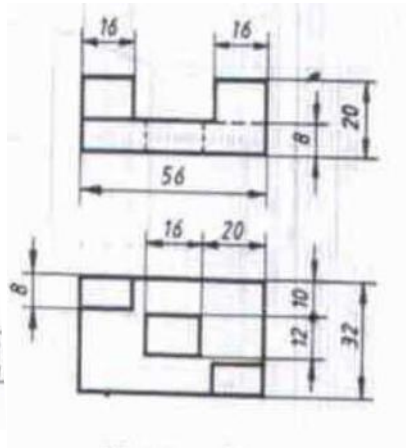

FIG-3

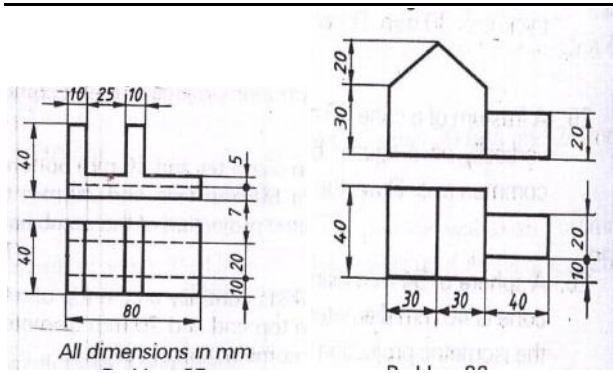
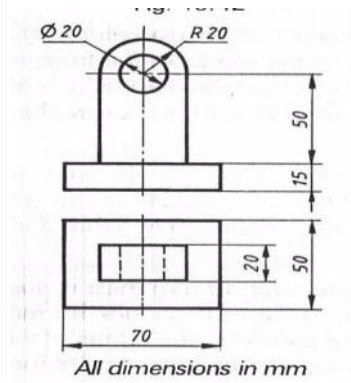

FIG-4

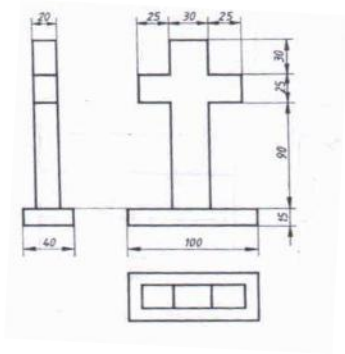

FIG-5

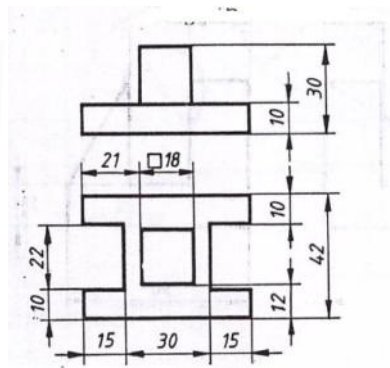

FIG-6

FIG-7

FIG-8

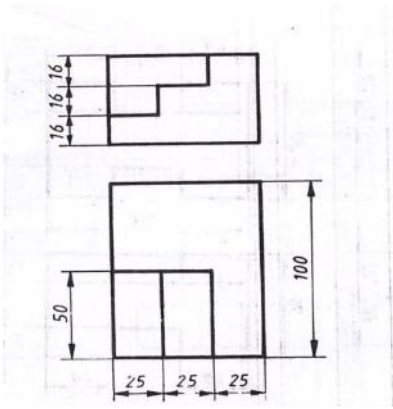

FIG-09

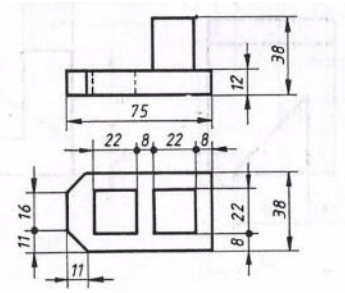

FIG-10

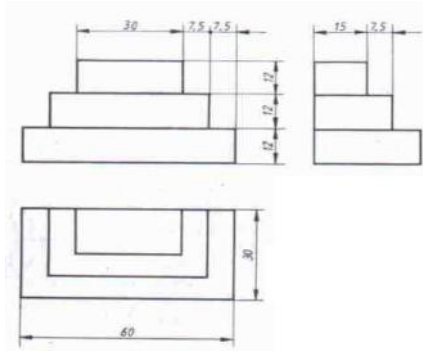
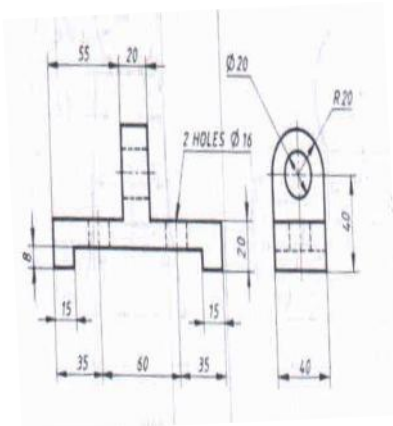

FIG-11FIG-12

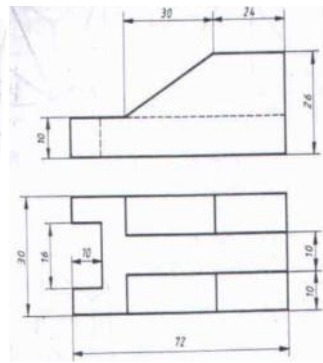
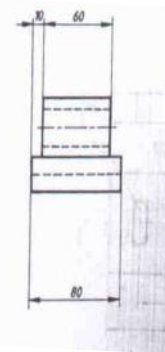
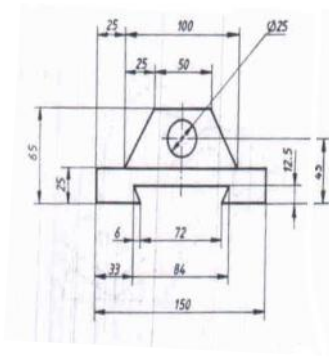

FIG-13FIG-14

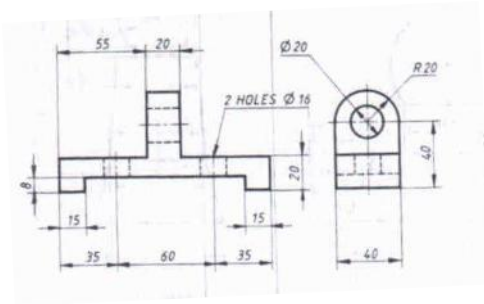

FIG-15

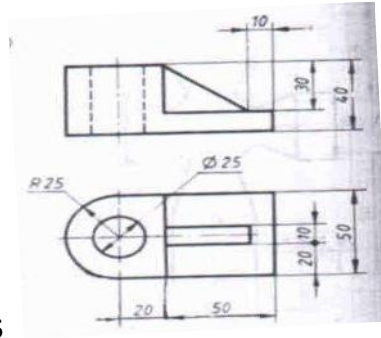

FIG-16

21. Draw the isometric view of a frustum of a cone of 40 mm top diameter, 80 mm bottom diameter and 60 mm height.
22. A cube of side 30 mm rests centrally on the top of another cube of side 60 mm. Draw the isometric view of the solid.
23. A square pyramid of base edge 50 mm and height 80 mm rests on the top of the cube of side 100 mm. Two sides of the base of the pyramid are parallel to the top edges of the cube. Draw the isometric view of the solid.
24. A cylindrical block of 40 mm diameter and length 50 mm is resting vertically on the centre of the cube of 70 mm side. Draw the isometric view of the combination of solids.
25. A square pyramid of base side 22 mm and height 20 mm rests centrally on the top of a cylinder of base diameter 40 mm and height 30 mm.

