

Government of Karnataka
Department of Collegiate and Technical Education
Board of Technical Examinations, Bangalore

Course Code	20ME02P	Semester	I/II
Course Title	Computer Aided Engineering Graphics	Course Group	CS,EC,EE & Other allied branches
No. of Credits	4	Type of Course	Lecture & Practice
Course Category	PC	Total Contact Hours	6Hrs PerWeek
			78Hrs Per Semester
Prerequisites	Enthusiasm to learn the subject/Visualizing/Creativity	Teaching Scheme	(L: T:P) = 1:0:2
CIE Marks	60	SEE Marks	40

1. COURSE RATIONALE:

Engineering Drawing is an effective language of engineers. It is the foundation block which strengthens the engineering & technological structure. Moreover, it is the transmitting link between ideas and realization.

2. LIST OF COMPETENCIES:

The course content should be taught and implemented with the aim to develop different types of skills leading to the achievement of the following competencies:

1. Prepare engineering drawings both manually and using CAD with given geometrical dimensions using prevailing drawing standards and drafting instruments.
2. Visualize the shape of simple object from orthographic views and vice versa

3. COURSE OUT COMES:

CO1	Adopt the standards, dimensioning and construct appropriate drawing scales, in technical drawing development.
CO2	Visualize objects in all planes and learn displaying techniques for graphical communication in design process.
CO3	Sketch orthographic projections into isometric projections and vice versa.
CO4	Use computer software and Apply computer aided drafting tools to create 2D/3 D engineering drawings

4. INSTRUCTIONAL STRATEGY:

1. Teacher should show model of real of the component/part whose drawing is to be made. Emphasis should be given on cleanliness, dimensioning and layout of sheet.
2. Focus should be on proper selection of drawing instruments and their proper use.
3. The institute should procure AutoCAD or other engineering graphics software for practice in engineering drawings.
4. Separate labs for practice on Engineering graphics Software should be established.

5 COURSE DETAILS:

The following topics/sub topics is to be taught and assessed in order to develop Unit Skill sets for achieving CO to attain identified skill sets

Unit	Major Learning Topics and Sub-Topics	Outcomes (in cognitive domain)	Hours L-T-P
UNIT-1 Basic elements of Drawing	1.1 List the different drawing instruments and application 1.2 Convention of lines and its application (Thick, Thin, Axis etc.) 1.3 Practice use of drawing instruments 1.4 Representative fraction Scales - Full Scale, Reduced Scale and Enlarged Scale 1.6 Dimensioning a) Aligned system and Unidirectional system in the Sketches b) Chain dimensioning and Parallel dimensioning 1.7 Construct different polygons	1. Drawing equipment's, instruments and materials. 2. Equipment's-types, specifications, method to use them, applications. 3. Instruments-types, specifications, methods to use them and applications. 4. Pencils-grades, applications, Different types of lines. 5. Scaling technique used in drawing. 6. Dimensioning methods. - Aligned method. Unilateral with chain, parallel dimensioning. 7. Constructions of geometrical figures	4-0-8
UNIT-2 CAD Interface	22.1 Introduction to CAD- Hardware requirements. 2.2 Various CAD software available 2.3 Familiarization of CAD window - Commands like New file, Saving the file, opening an existing drawing file, Creating templates 2.4 Setting up new drawing: Units, Limits, Grid, Snap. Standard sizes of sheet. 2.5 Selecting Various plotting parameters such as Paper size, paper units, drawing orientation, plot scale, plot offset, plot area, print preview	1. CAD-Definition-Importance. 2. Familiarization with CAD Environment and utilities. 3. Setting up layout in CAD software's by taking plotting parameters	4-0-8
UNIT-3 Exposure to CAD Commands	3.1 Draw basic entities like Line, Circle, Arc, Polygon, Ellipse, Rectangle, Multiline, Dimensioning, Inserting text Applying constraints - horizontal, vertical, parallel, concentric, perpendicular, symmetric equal, collinear 3.2 Insert title block for the drawing and take the Print out 3.3 Create objects by applying constraints and convert the objects to full scale, reduced scale and enlarged scale 3.4 Apply copy, mirroring, array, fillet and trim on the object created	1. Computer graphics & its terminology. 2. CAD definition, concept & need. 3. Commands used in CAD 4. Functional areas of CAD.- Coordinate systems. 5. Familiarization of Cad commands 6. Draw simple Geometrical figures using CAD	6-0-12
UNIT-4 Orthographic projections	4.1 Introduction to orthographic projection 4.2 Conversion of pictorial view into Orthographic Views	1. Types of projections- orthographic concept and applications. 2 Various term associated	4-0-8

		<p>with orthographic projections.</p> <p>(a) Theory of projection.</p> <p>(b) Methods of projection.</p> <p>(c) Orthographic projection.</p> <p>(d) Planes of projection.</p> <p>3. Conversion of simple pictorial views into Orthographic views. Illustrative problems on orthographic projection.</p> <p>Note :</p> <p>(1) Problem should be restricted up to - Front view/Elevation, Top view/Plan and Side views only.</p> <p>Use First Angle Method only.</p>	
UNIT-5 Isometric projections	<p>5.1 Introduction to Isometric Projections</p> <p>5.2 Isometric Scales and Actual Scale</p> <p>5.3 Isometric View and Isometric Projection</p> <p>5.4 Conversion of Orthographic Views into Isometric</p>	<p>1. Isometric axis, lines and planes.</p> <p>2. Isometric scales.</p> <p>3. Isometric view and isometric drawing.</p> <p>4. Difference between isometric projection and isometric drawing.</p> <p>5. Illustrative problems limited to Simple elements</p>	4-0-8
UNIT-6 CAD Drafting	<p>6.1 Draw different types of 2D/3D modeling entities using viewing commands, to view them (Problems solved in chapter no 3 and 4 i.e Orthographic, isometric projection).</p> <p>6.2 2D/3D modeling for Branch specific components</p>	<p>1 Difference between 2D & 3D models.</p> <p>2. 2D/3D modeling – concept, Simple objects</p>	4-0-8
		TOTAL	26-0-52

6. LIST OF PRACTICAL EXERCISES:

The exercises/practical/experiments should be properly designed and implemented with an attempt to develop different types of skills leading to the achievement of the competency. Following is the list of exercises/practical/experiments for guidance.

Sr. No	Unit No.	Practical Exercises (Outcomes in Psychomotor Domain)	Hours
1	1	1. Teacher will demonstrate a: Use of a. Drawing instruments. b. Planning and layout as per IS. c: Scaling technique.	1-0-2
		2. Draw following. Problem – 1 Drawing horizontal, vertical, 30 degree, 45 degree, 60 & 75 degrees lines using Tee and Set squares/ drafter. (Sketch book)	
		Problem – 2 Indicate different convention of lines on the drawing. (Sketch Book)	1-0-2
		Problem – 3 Copy the sketch to the required scale and dimensioning adopting right system and positioning of dimensions using Tee and Set squares / drafter. (Sketch Book)	1-0-2

		Problem 4. Draw regular geometric constructions Pentagon, Hexagon, Square, circle, Triangle and other shapes. (SketchBook)	1-0-2
2	2	Use of CAD commands, plotting the drawing	4-0-8
3	3	Problem 5: Drawing basic entities: Circle, Arc, Polygon, Ellipse, Rectangle, Multiline	6-0-12
4	4	Problem 6: Draw Orthographic views for the given object. (CAD Drawing) (Minimum 5 Problems)	4-0-8
5	5	Problem 7: Draw Isometric projections for the given Orthographic views (CAD Drawing) (Minimum 5 Problems)	4-0-8
6	6	Problem 8: Produce Orthographic (2D) Drawings in CAD – Chap 3 Problem 14: Produce Isometric and 3D Drawings in CAD – Chap 4 (CAD Drawings and Printout) (Minimum 5 Problems)	2-0-4
		Problem 9: create 3D models of Program specific Elements such as Panel box (Minimum 3 Problems related to Program specific)) (CAD Drawings and Printout)	2-0-4
		TOTAL	26-0-52

- 1 Theory & practice should be in first angle projections and IS codes should be followed wherever applicable.
- 2 The dimensions of line, axes, distances, angle, side of polygon, diameter, etc. must be varied for each student in batch so that each student will have same problems, but with different dimensions.
- 3 The sketchbook has to contain data of all problems, solutions of all problems and student activities performed.
- 4 Students activities are compulsory to be performed.

7. SUGGESTED LIST OF STUDENT ACTIVITIES:

SL.NO.	ACTIVITY
1	Sketch the combinations of sets square to draw angles in step of 15°, 30°, 45°, 60°, 75°, 90°, 105°, 120°, 135°, 150°, 165°, 180°.
2	Take two simple objects. Sketch isometric of them.
3	Take two simple objects. Sketch Pictorial orthographic views of them.
4	Prepare a 2D drawing using AutoCAD and 2D parametric sketcher environment.
5	Prepare 3D solid models using AutoCAD any one mechanical component (Four components).

8. SUGGESTED LEARNING RESOURCES:

- 1 Bureau of Indian Standards. *Engineering Drawing Practice for Schools and Colleges IS: Sp-46*. BIS. Government of India, Third Reprint, October 1998; ISBN: 81-7061-091-2.
- 2 Bhatt, N. D. *Engineering Drawing*. Charotar Publishing House, Anand, Gujrat 2010; ISBN: 978-93-80358-17-8.
- 3 Jain & Gautam, *Engineering Graphics & Design*, Khanna Publishing House, New Delhi (ISBN: 978- 93-86173-478)
- 4 Jolhe, D. A. *Engineering Drawing*. Tata McGraw Hill Edu. New Delhi, 2010; ISBN: 978-0-07-064837-1
- 5 Dhawan, R. K. *Engineering Drawing*. S. Chand and Company, New Delhi; ISBN: 81-219-1431-0.

6. Shah, P. J. *Engineering Drawing*. S. Chand and Company, New Delhi, 2008, ISBN:81-219-2964-4.
7. Kulkarni, D. M.; Rastogi, A. P.; Sarkar, A. K. *Engineering Graphics with AutoCAD*. PHI Learning Private Limited-New Delhi (2010); ISBN: 978-8120337831.
8. Jeyapoovan, T. *Essentials of Engineering Drawing and Graphics using AutoCAD*. Vikas Publishing House Pvt. Ltd, Noida, 2011; ISBN: 978-8125953005.
9. Autodesk. *AutoCAD User Guide*. Autodesk Press, USA, 2015.
10. Sham, Tickoo. *AutoCAD 2016 for Engineers and Designers*. Dreamtech Press; Galgotia Publication, New Delhi, 2015; ISBN 978-9351199113.

9. SOFTWARE/LEARNING WEBSITES :

1. <https://www.youtube.com/watch?v=TJ4jGyDWCw>
2. https://www.youtube.com/watch?v=dmt6_n7Sgcg
3. https://www.youtube.com/watch?v=_MQScnLXL0M
4. <https://www.youtube.com/watch?v=3WXPanCq9LI>
5. <https://www.youtube.com/watch?v=fvjk7PlxAuo>
6. <http://www.me.umn.edu/coursesme2011/handouts/engg%20graphics.pdf>
7. <https://www.machinedesignonline.com>

10. Mapping of Course Outcomes with Programme Outcomes (Suggestive only):

Course	CO's	Programme Outcomes(PO's)						
		1	2	3	4	5	6	7
Engineering Graphics	CO1	3	0	0	3	0	0	0
	CO2	3	0	0	3	0	0	0
	CO3	3	0	0	3	0	0	0
	CO4	3	0	0	3	0	0	0
Level 3- Highly Mapped, Level 2-Moderately Mapped, Level 1-Low Mapped, Level 0- Not Mapped								
<p>Method is to relate the level of PO with the number of hours devoted to the CO's which maps the given PO.</p> <p>If $\geq 50\%$ of classroom sessions related to the CO are addressing a particular PO, it is considered that PO is mapped at Level 3</p> <p>If 30 to 50% of classroom sessions related to the CO are addressing a particular PO, it is considered that PO is mapped at Level 2</p> <p>If 5 to 30% of classroom sessions related to the CO are addressing a particular PO, it is considered that PO is mapped at Level 1</p> <p>If $< 5\%$ of classroom sessions related to the CO are addressing a particular PO, it is considered that PO is considered not-mapped i.e., Level 0</p>								

11. COURSE ASSESSMENT AND EVALUATION CHART:

Sl. No	Assessment	Time frame in semester	Duration	Max marks	Conversion
1.	Portfolio Evaluation of Drawings (CAD Practice Exercises)	Entire Duration	-	20	20
2	Skill Test-1 (Skill test 1 is of CAD based-Unit-2)	At the end of 4 th week	3 Hrs	100	Average of two skill tests 1 and 2 (Both skill tests are to be reduced to weightage of 20 independently) 20
3	Skill Test-2 (Skill test 2 is of CAD based-Unit,3,4)	At the end of 8 th week	3 Hrs	100	

4	Skill Test-3 (Skill test 3 is of CAD based Unit 5,6)	At the end of 13 th week	3 Hrs	100	Skill tests-3 is to be reduced to weightage of 20
5	Total Continuous Internal Evaluation (CIE) Assessment				60
6	Semester End Examination (SEE) Assessment conducted for 100 marks, finally reduced to 40 marks weightage		3 Hrs	100	40
				TOTAL	100

Scheme of Valuation for End Examination

SL NO	QUESTIONS	MARKS
1.	Create Orthographic views for the given Pictorial drawing. Indicate all Dimensions and Annotations.(CAD)	50
OR		
	Create Isometric Projections for the given Orthographic views (CAD)	50
2.	Create 3D drawing for the given Sketch (CAD)	50
		TOTAL
		100

12. CAD Laboratory and Other Requirements to Conduct Engineering Graphics Course

1. Latest Configuration Computers which can be able to run latest any Computer Aided Drafting Software. (At least One Computer per student in practical session.)-30 no
2. Any latest Authorized Computer Aided Drafting Software (30 user licenses)
3. Plotter of size A2/A3
4. LCD Projector.

MODEL QUESTION BANK (Suggestive only)

1. Draw six horizontal parallel lines of 50 mm long with 10 mm intervals (Fig 1).



2. Draw six vertical parallel lines of 50 mm length with 10 mm intervals (Fig 2)



3. Draw 45° inclined lines (Fig 3).

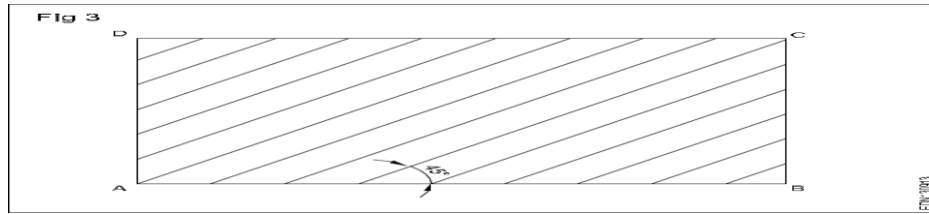

4. Draw the given types of lines using 0.5 range thickness of line according to the specification (Fig 4).

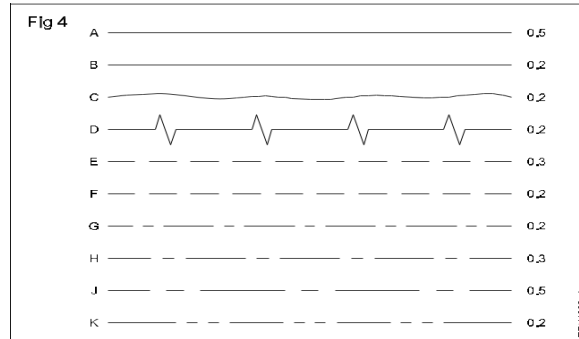

5. Draw the following Exercises in A4 sheet (Fig 5).

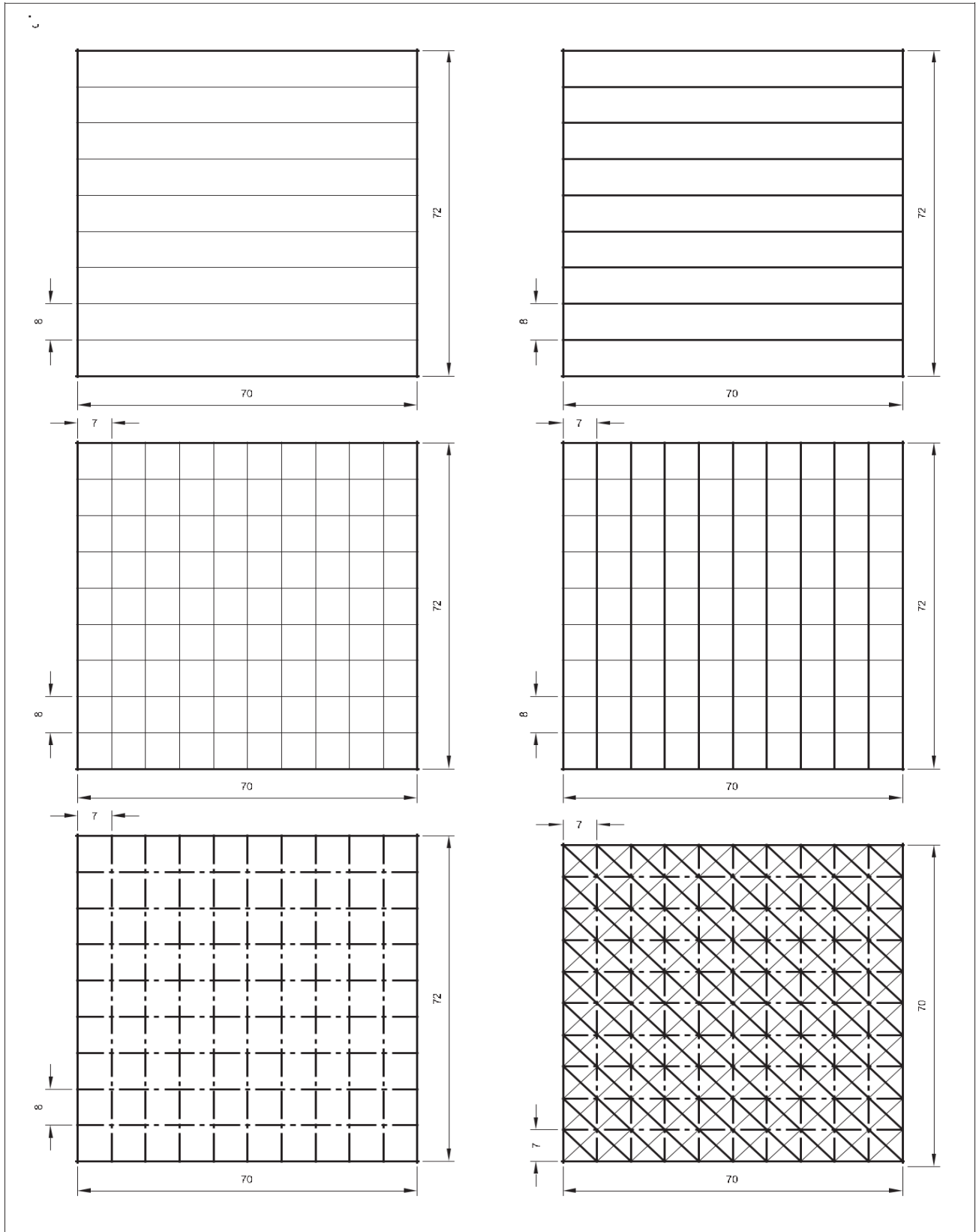

6a) Illustrate the elements of dimensioning with the help of a sketch.

b) Illustrate the dimensioning of given common features: diameter, radius, chord, Arc and angle.

7. Copy the sketch to 1:1 scale and dimension it using Aligned system.

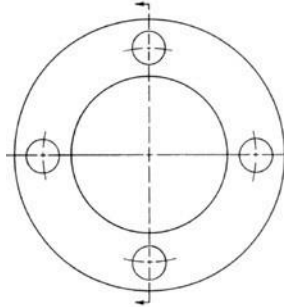

8. Copy the sketch to 1:1 scale and dimension it using unidirectional system with Parallel dimensioning method.

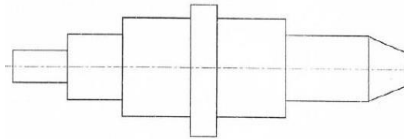

9. Copy the sketch to 1:1 scale and dimension it using Aligned system with Chain dimensioning method.

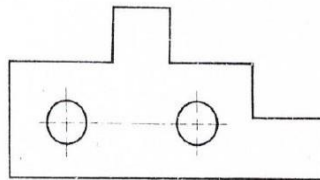

10. Copy the sketch to 1:1 scale and dimension it using Aligned system with Parallel dimensioning method.

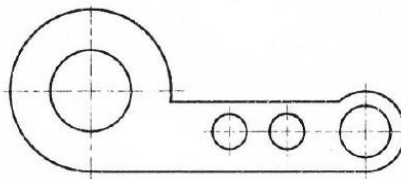

11. Copy the sketch to 1:1 scale and dimension it using unidirectional system with Chain dimensioning method

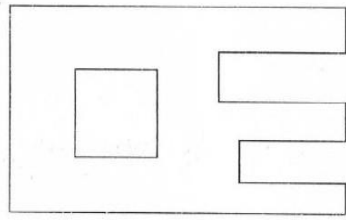

12. Copy the sketch to 1:1 scale and dimension it using unidirectional system with Parallel dimensioning method.

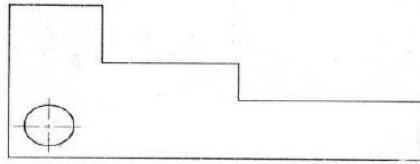

ORTHOGRAPHIC ROJECTIONS

1. Draw the three principal views of the component as shown in the figure.

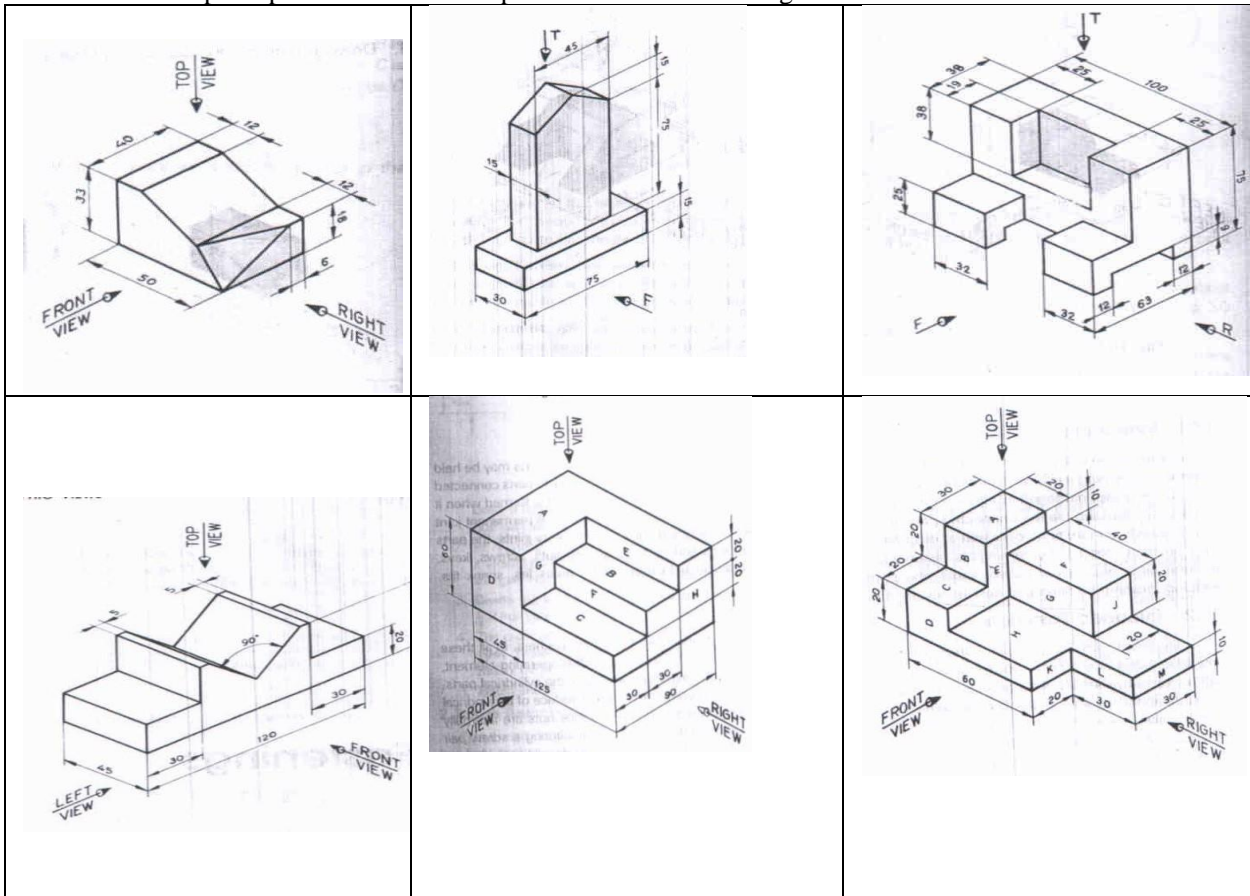

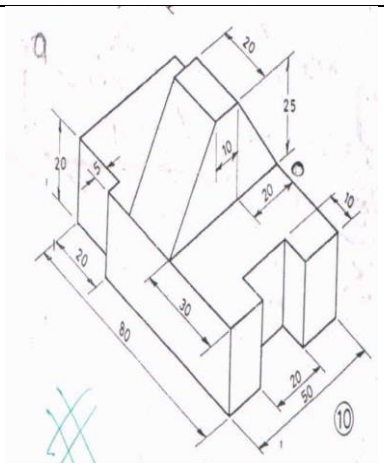
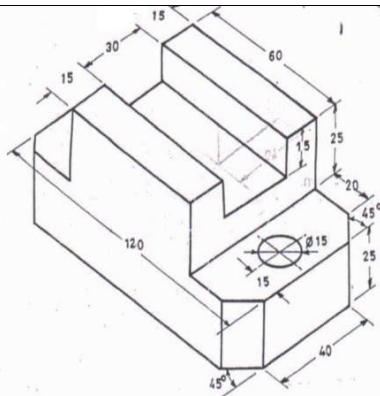
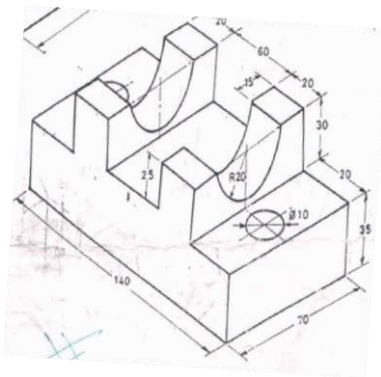
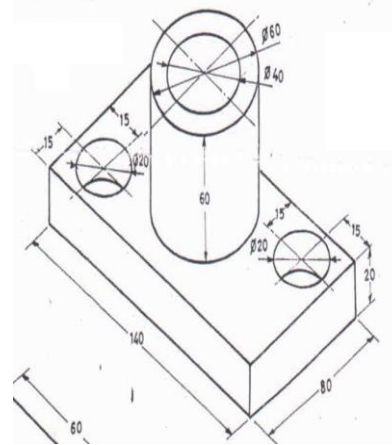
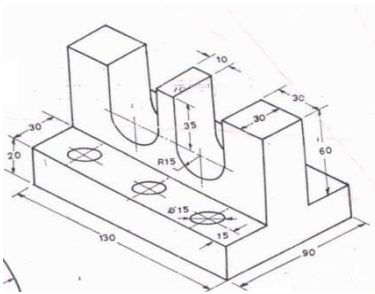
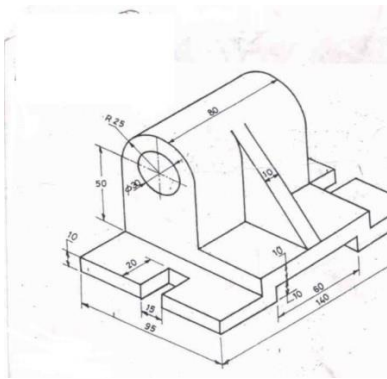
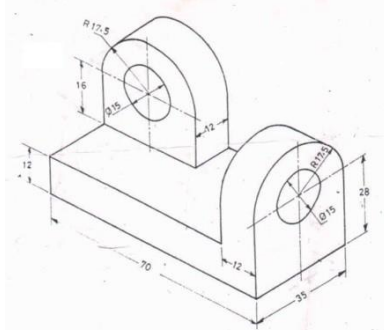
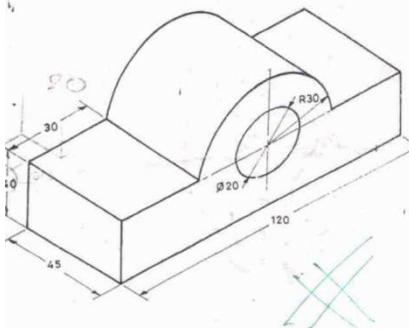
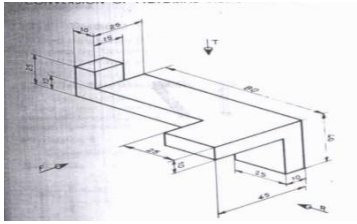

ISOMETRIC PROJECTIONS

1. Draw the isometric view of the machine component whose orthographic views are given below:

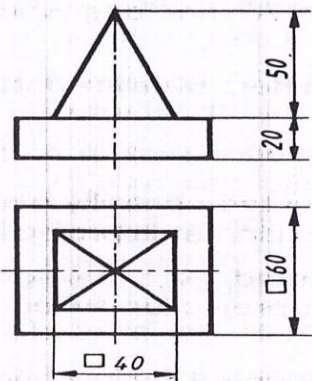
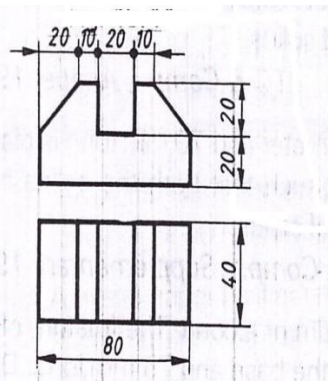
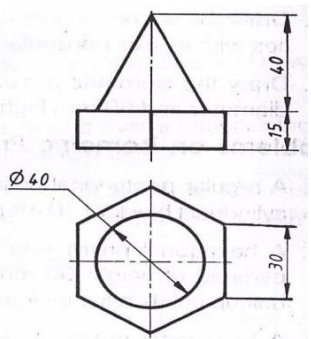
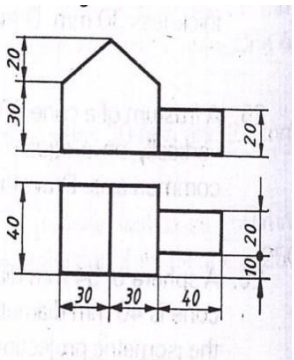
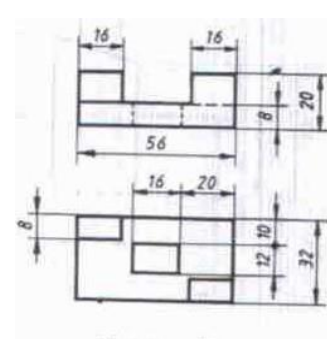
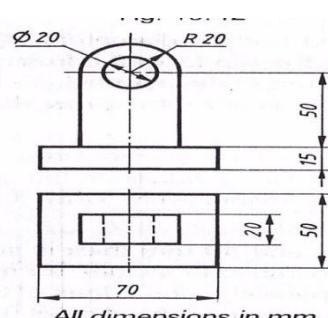
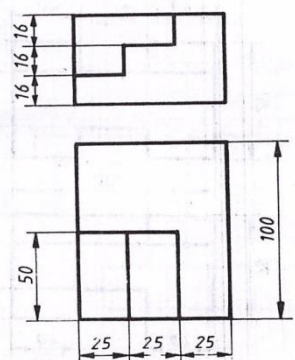
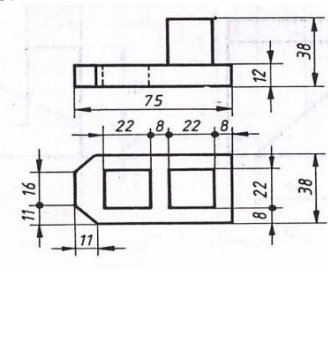
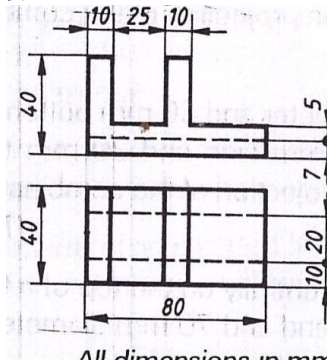
<p>1.</p> 	<p>2.</p> 	<p>3.</p> 
<p>4.</p> 	<p>5.</p> 	<p>6.</p>  <p style="text-align: center;"><i>All dimensions in mm</i></p>
<p>7.</p> 	<p>8.</p> 	<p>9.</p>  <p style="text-align: center;"><i>All dimensions in mm</i></p>

2. Draw the isometric Projection of the machine component whose orthographic views are given below:

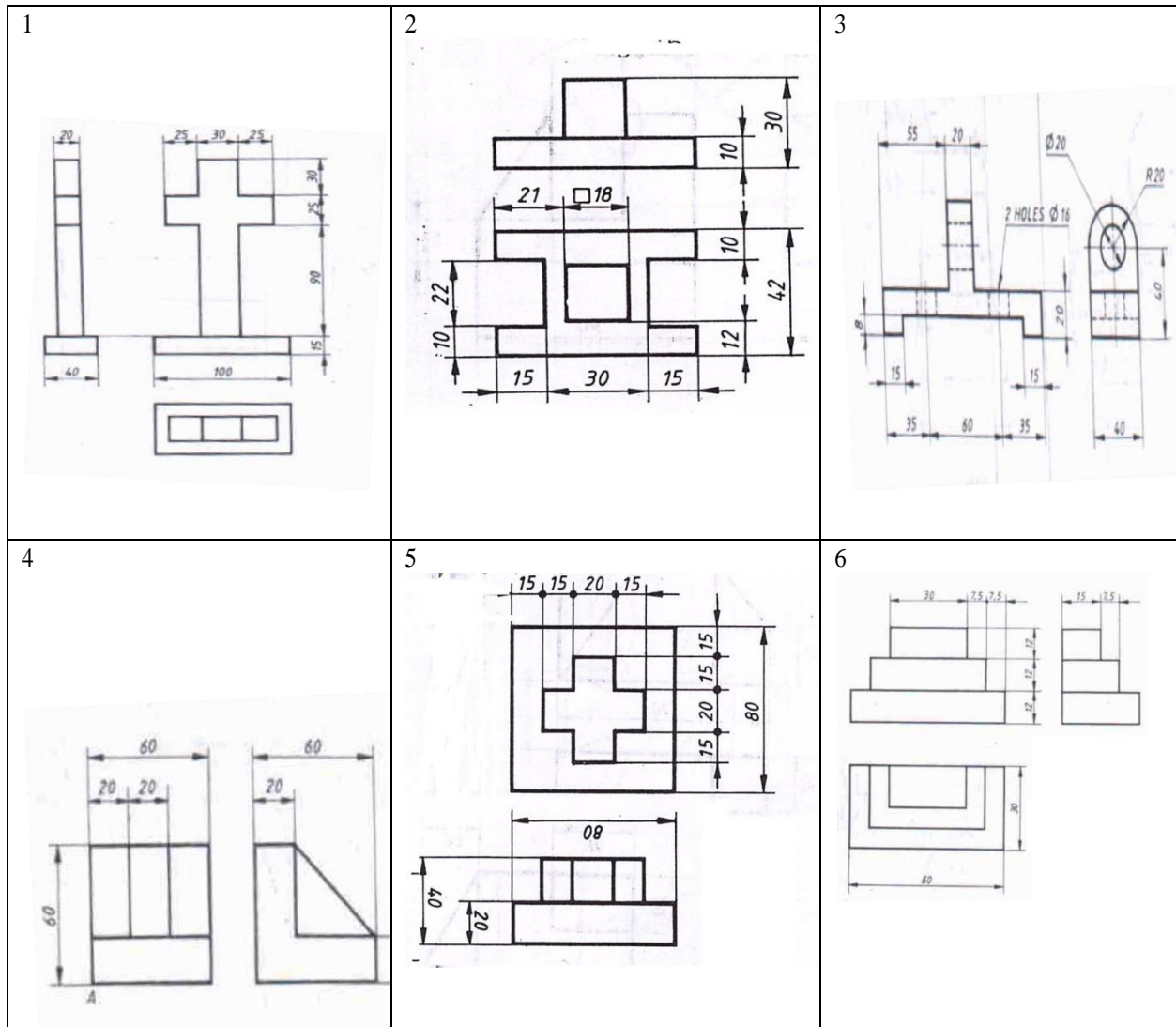

3. Draw the isometric Projection of the machine component whose orthographic views are given below

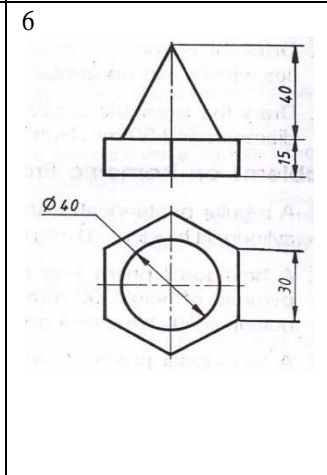
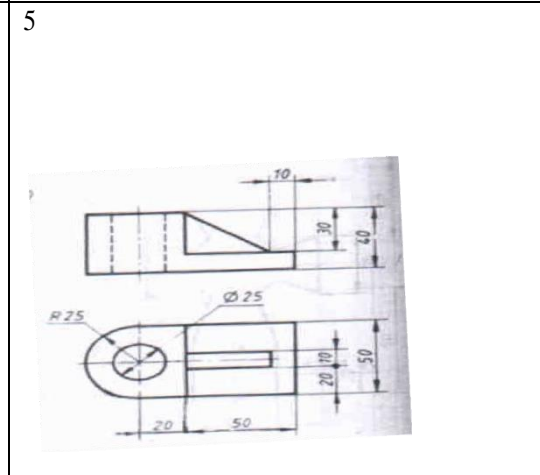
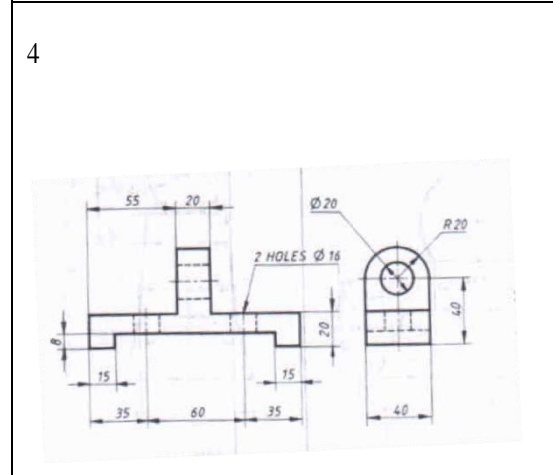
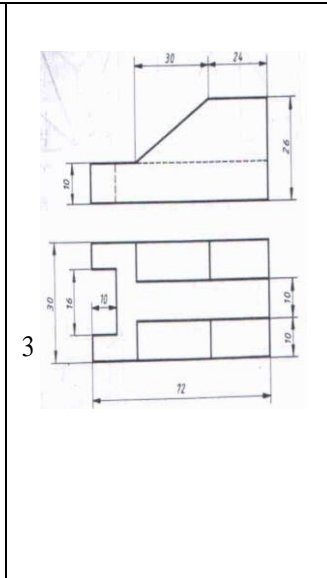
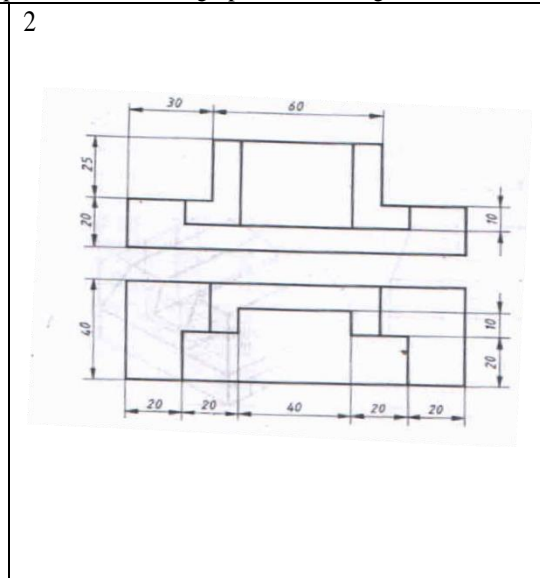
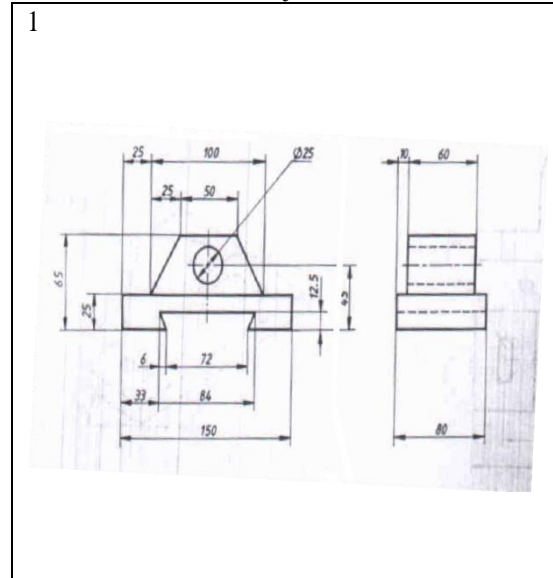

Draw the isometric View of the machine component whose orthographic views are given

